

GJD Lensmeter

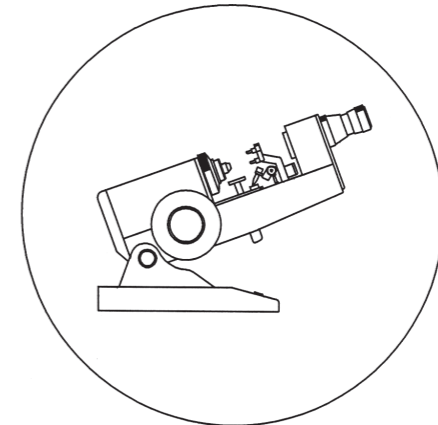

Operating Instruction

1、 Instrument overall and construction

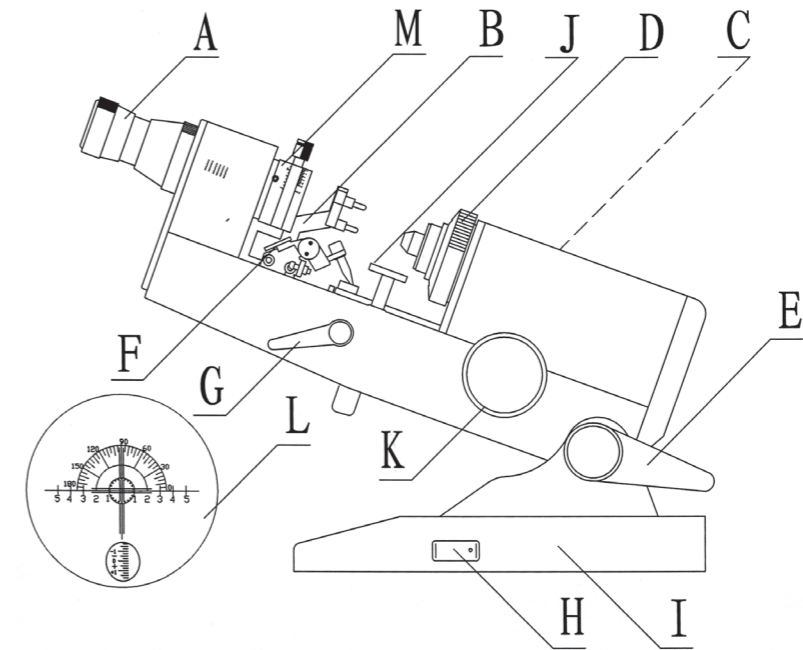

- | | |
|------------------------------------|-------------------------------------|
| A、 eyepiece | G、 elevating handle of lens table |
| B、 fixed handle of lens | H、 switch |
| C、 scale disc(for outer reading) | I、 base |
| D、 antigmatism axis measuring knod | J、 lens table |
| E、 position-fixed handle | K、 diopter measuring knob |
| F、 print device | L、 display window for inner Reading |
| M、 prism (optional) | |

2. Reading Mode Digital Lensmeter Reading Window and Button' Operation

For inner reading, outer reading and digital lensmeter, their technical performance and construction are the same, and the difference is made on the reading mode, which this data is read out on the scale disc of diopter measuring knob for outer reading, on the eyepiece reticle for inner reading, and through the display window for digital lensmeter.

Digital lensmeter may display $0 \sim \pm 25.00D$ in the window, reading resolution is $0.01D$.

Beside the reading window, the down button is "0" Enter one (Before leaving factory, "0" has been entered), press this button, the diopter is in

“0” location. The upper button is astigmatism measuring one. When the lens inspected is astigmatic, firstly adjust it to the location of low diopter, press this button, display winking letter “C” in the left-up comer of reading window, at this time, the window will indicate to measure its diopter, and then continuously turn it to the location of high diopter, press again this button, the single-chip will automatically count the numerical value, directly show out the astigmatic diopter of the inspected lens in the window.

Note:1.For the operating method, please refer to Operating Instruction “Measure astigmatic doopter and astigmatism axis of cylindric lens” ;

2.If you find that the screen is not shown, please open the base cover and replace a new battery.(the use life is 18-24 months for a 5# battery.).

3.Usages

GJD lensmeter can assay spherical lens or cylindric lens diopter of spectacles, astigmatism axis of cylindric lens, prism diopter and base direction, and mark the optical center, axis of cylindric lens and prism base direction. If attached with the accessories, also may measure diopter of cornea-contact lens.

This instrument, easy in operating, sharp in imaging, stable in performance, is suitable for spectacles measurement detection department, spectacle processing factories, spectacles sales departments, departments of ophthalmology in hospital and optical element factories.

4.Main Technical Specifications

| | |
|--------------------------------|---|
| ● Ranges of Measurement: | 0 to ±25D |
| ● Minimum: ▲ Outer Reading | 0.125D |
| ▲ Inner Reading | 0.125D graduation up 0 to ±5D and 0.25D graduations over ±5D to ±25D |
| ▲ Digital | 0.01D |
| ● Cylinder Axis Range: | 0-180° step 1° |
| ● Prismatic Power Range: | ▲ 0-5△ prism diopters, 1△ graduations ▲ with prism compensation device 0-20△ prism diopters, 1△ graduations |
| ● Prism Base Angle: | 0-180° |
| ● Eyepiece Adjustment: | ±5D |
| ● Dimension of Objective Lens: | 16~86mm |
| ● Overall Size: | 220×120×430mm |
| ● Weight: | 4kg |
| ● Lighting Bulb: | -220V-3V 3W or-110V/-3V 3W |

5.Adjustment before operating

1) View speed adjustment of eyepiece: Due to different person's vision, before measurement, rotate the view speed ring of eyepiece reticle in the view field. Shown as Fig.3

2) Adjust “zero” position of diopter: Rotate the diopter measuring knob till the image of objective reticle (green, bright image) is the clearest, shown as Fig.4. At this time, the zero diopter on the scale disk of diopter measuring knob aims at the indication line

3) Correct regularly this instrument's technical parameters with standard lens.

6. Operating methods (If the operator's eyes are astigmatic, please put on his corrective spectacle before measurement.)

◆ Insert the power wire to 220V (or ~110V) 50HZ socket, then turn on the switch on the base;

◆ Adjust view speed of eyepiece till clearly observe the image of eyepiece reticle;

◆ Measure the vertex diopter of spherical lens;

1) Place the inspected lens on lens table, and regulate the height of the table to combine the lens center and optical axis center. If not, move the position of lens up and down or left and right, and then drive knurling screw to clamp the lens.

2) Turn the diopter measuring knob until observe the sharpest image of objective reticle in the eyepiece, show as Fig.3, at this time, the reading on the scale disc of diopter measuring knob is the vertex diopter of this lens.

3) After combining two image centers of objective reticle and eyepiece reticle, make the optical center of the lens.

◆ The measuring astigmatic degrees of the cylinder lenses and their axes

1) The astigmatic degrees of cylinder lenses mean that there are different numerical values on some sections that are vertical to each other. Measure the diopters of these two directions separately and the differences between them are the astigmatic degrees of the cylinder lenses (Fig.5, Fig.6)

2) When the astigmatic lenses are measured, the target resolving

pictures cannot always be adjusted cleanly, Then you can see the small points (like long small lines)on the target resolving Pictures. Rotate the Axial Handwheel (D) to the same direction as the lines and shift the long crosslines to the same angles as the small points. At this time a long direction line appears clearly; if you go on to adjust the Diopter Handwheel(K) until the other long direction line appears clearly. There are two numerical values appearing on the diopter dial: The difference between them is just the astigmatic degrees while the higher numerical values appear clearly with the long lines, whose directions are the astigmatic axes(Fig.5)

3) The locations of the astigmatic axes are indicated through angles from 0° to 180°. Every graduation of the instrument is 1°. When the astigmatic axis is determined, please adjust the Axial Handwheel(D) and the axis required can point the long crossline at the axial angle (Take the graduation in the eyepieces as the standard while the axial graduation on the Handwheel as the reference).

Take the higher value of diopter as the location of axis. If it is not clearly, rotate the lenses till they are clearly enough. Meanwhile, you can stamp them with the signs by the point Axis Stamp(F)

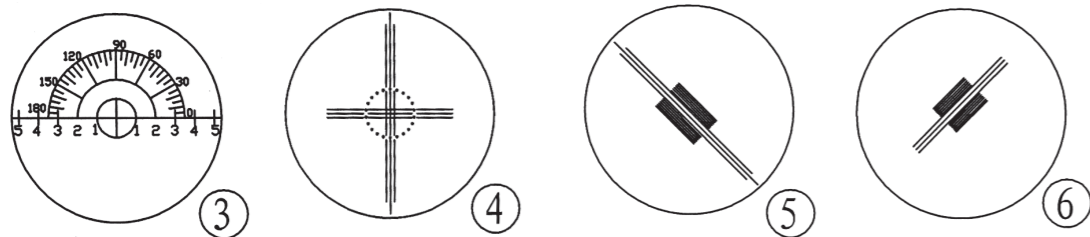

This samples are listed for reference.

| No. | the Higher Diopter(D)(of Cylindric Lens) | the Lower Diopter(D)(of Spherical Lens) | AstigmaticDiopter(D) |
|-----|--|---|----------------------|
| 1 | -3.75 | -3.25 | -0.5 |
| 2 | +2.5 | +2.0 | +0.5 |
| 3 | -0.75 | +0.25 | -1.0 |
| 4 | +0.5 | -0.5 | +1.0 |
| 5 | +1.25 | -0.5 | +1.75 |

◆ Measure prism diopter and base direction

Place the inspected lens on the lens table, adjust the height of the table to combine the lens center and optic axis, and then clamp this lens. At this time, you will observe that the center of object reticle deviates from the center of eyepiece reticle through eyepiece. Turn the lens to make three lines of object reticle on the horizontal (or vertical) line of eyepiece reticle, and the object reticle center deviate from eyepiece reticle center, shown as Fig.7, the number of deviation interval is called prism diopter. Mark three dots, and that line connecting three dots is called the base direction of prism.

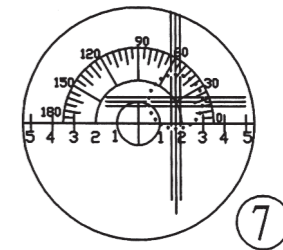

7. Maintenance

1). If you find the lamp isn't bright, firstly check the fuse behind the base.

2). The instrument must be kept in shade, cool and dry place, free of dust, acid, alkali and vapor. Avoid strong vibration.

3). The instrument must be kept clean. The dust of optical surface can be blown by a balloon or should be cleaned off with a soft hair brush, the dirty can be wiped off gently with lens tissue moistened with xylene.

4). The instrument should not be disassembled by the user. Any examination or repair which might become necessary should be entrusted to our factory or other special department.

8. Complete Set

- (1) Lensmeter
- (2) Operating Instruction
- (3) Spare fuse and bulb (1 each)