

# SLIT LAMP INSTRUCTION MANUAL



## Preface

Thank you for purchasing our Slit Lamp. To prevent damage to your product or injury to yourself or to others, read the following safety precaution in their entirety before using this equipment. Keep these safety instructions where all those who use the product will read them.

---

### Precautions

---

1. Do not use this instrument in the environment prone to fire and blast or where there is much dust and with high temperature. Use it in the room and simultaneously be careful to keep it clean and dry.
2. Check that all the wires are correctly and firmly connected before using. Ensure that the instrument is well grounded.
3. Please pay attention to all the rating of the electrical connecting terminal.
4. Only use fuse according to the specifications and rated values stipulated by our product.
5. Use the power cable supplied with this instrument.
6. Do not touch the surface of the lens and prism with hand or hard objects.
7. Turn off the main power first before replacing the main bulb, flash lamp and fuse.
8. Turn off the power and cover the instrument with dust-prove hood when it is not in use.
9. In case there is any trouble, please first refer to the trouble-shooting guide. If it still can't work, please contact with the authorized distributor or our Repair Department.



Caution



terminal of the  
grounding



illuminator



type B

## contents

<b>1 PURPOSE</b> .....	<b>1</b>
<b>2 NAMES OF CONTROLS AND COMPONENTS</b> .....	<b>1</b>
<b>3 ASSEMBLY</b> .....	<b>3</b>
3.1 Selecting voltage and fuse .....	4
3.2 Assembling the worktop and Head-rest part .....	4
3.3 Assembling the Shaft part.....	5
3.4 Assembling the base part and the rail covers .....	5
3.5 Assembling the binocular tube .....	6
3.6 Assembling illumination part .....	6
3.7 Removing the illumination part shipping pad .....	6
3.8 Connecting plug.....	7
3.9 Assembling the chin-rest paper .....	7
3.10 Checking procedure after assembling.....	7
<b>4 OPERATION PROCEDURES</b> .....	<b>8</b>
4.1 Diopter compensation and pupil distance adjustment .....	8
4.2 Patient position and fixation target.....	9
4.3 Base operation .....	10
4.4 Operation illumination unit .....	10
<b>5 MAINTENANCE</b> .....	<b>13</b>
5.1 Replacing the illumination bulb .....	13
5.2 Replacing the reflecting mirror.....	13
5.3 Replacing the fuse .....	14
5.4 Replacing the chin-rest paper .....	14
5.5 Consumables.....	15
5.6 Adjusting the tightness of the slit width knob .....	15
5.7 Cleaning.....	15
<b>6 TROUBLE SHOOTING GUIDE</b> .....	<b>16</b>
<b>7 REPAIR</b> .....	<b>16</b>
<b>8. TECHNICAL SPECIFICATION</b> .....	<b>17</b>
<b>9. EMC (ELECTROMAGNETIC COMPATIBILITY)</b> .....	<b>18</b>

## 1 Purpose

The Slit Lamp is an AC-powered Slit lamp biomicroscope and is intended for use in eye examination of the anterior eye segment, from the cornea epithelium to the posterior capsule. It is used to aid in the diagnosis of diseases or trauma which affects the structural properties of the anterior eye segment.



**Warning:** This device is intended to be used only by suitably trained and authorized healthcare professionals.

## 2 Names of controls and components

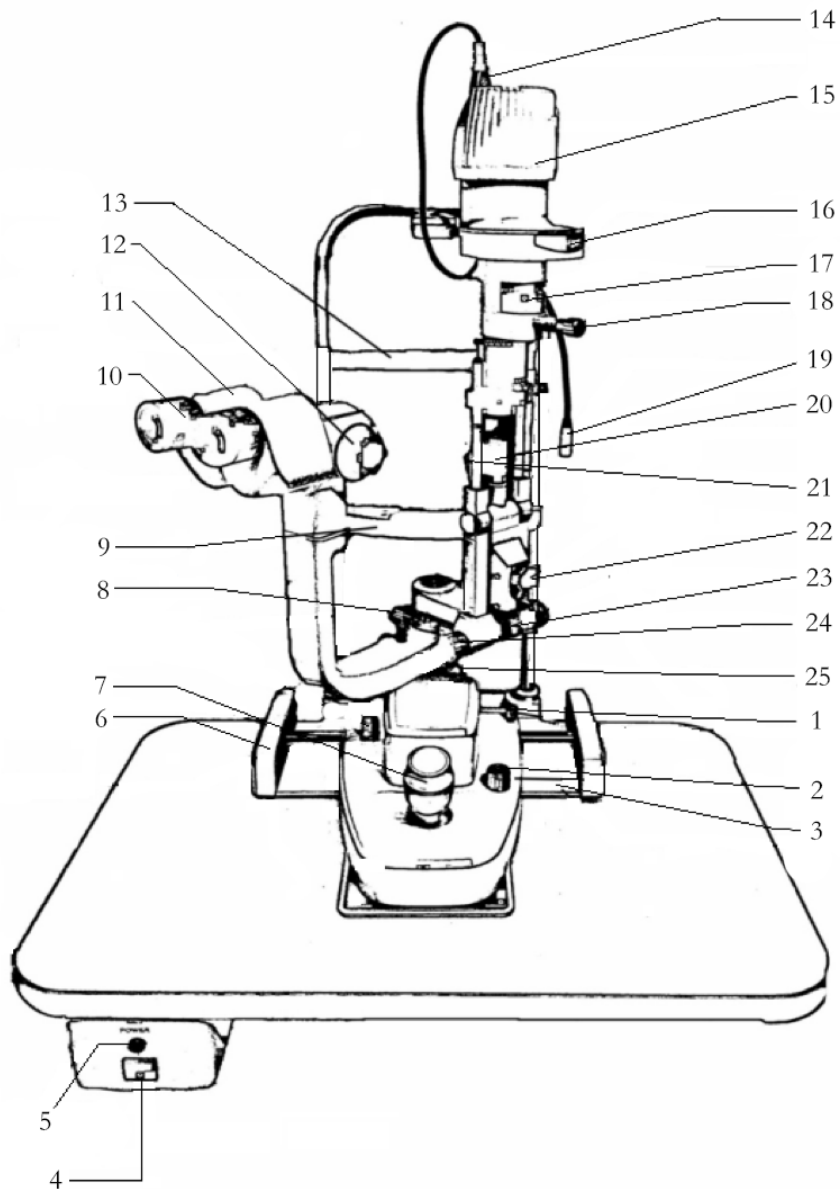

Fig 1

<b>No.</b>	<b>Components</b>
1	<b>Base Locking screw</b> The base will be locked when fastening this screw.
2	<b>Brightness Control Switch</b> The brightness can be continuous adjusted. Avoid working continuously at high setting, as service life of the bulb will be shortened.
3	<b>Worktop</b>
4	<b>Main Power Switch</b>
5	<b>Pilot Lamp</b>
6	<b>Rail Cover</b> Protect the rail surface.
7	<b>Omni-directional Joystick</b> For fine control of the instrument, incline this lever toward the intende direction. Turning the joystick controls the vertical movement.
8	<b>Microscope Arm Locking Knob</b> Lock the rotational movement of the arm.
9	<b>Chin-rest</b>
10	<b>12.5x Eyepiece</b> Before using the slit lamp, adjust the proper diopter for each eyepiece to obtain definite image.
11	<b>Prism box</b>
12	<b>Magnification Select Dial</b> Five different magnifications are provided.
13	<b>Forehead Rest</b>
14	<b>Lamp Cable</b>
15	<b>Lamp Cap</b>
16	<b>Aperture and Slit Length Display Window</b>
17	<b>Filter Selection Lever</b> There are four filter for selection
18	<b>Aperture and Slit Length Control Knob</b> Rotate this knob to adjust the spot and the slit height. Swing the konb horizontally to revolve the slit.
19	<b>Fixation target</b>
20	<b>Reflecting Mirror</b> Both long and short reflecting mirrors are provided. The long mirror is routinely used for most examination peocedures. The short mirror is used when the long mirror interferes with the observation pathway, such as during funduscopy.
21	<b>Diffusion lens</b> Used for observing and photographing at a low magnification, and for enlarging the illumination field.
22	<b>Centering Knob</b> Loosening the knob allows the illumination light to be moved from the center of

	the vision field for indirect retro-illumination. Fastening the knob brings the illumination light back to the center.
23	<b>illumination Inclination Lever</b> Four 5° inclination stops are available -up to 20°.
24	<b>Slit Width Control Knob</b> The slit width is continuously adjustable within the range from 0 to 14mm. The marks on the left knob stand for the approximate value of the width.
25	<b>Cross-Slide Base</b> Supports the slit lamp and illumination arms; moves in response with the joystick.

### 3 Assembly

These instructions are for assembling the Slit Lamp after all the components have been carefully removed from the shipping carton.



**Warning: The parts of slit lamp shall not be serviced or maintained while in use with a patient.**





**Warning: To avoid the risk of electric shock, this equipment must only be connected to a supply mains with protective earth.**







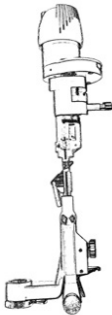
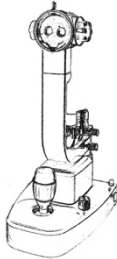
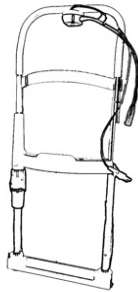
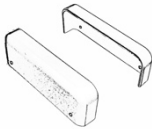
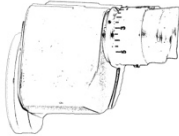

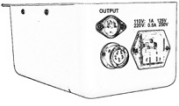
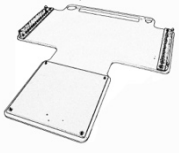

**Caution: Qualified trained professional persons are needed to maintenance the product. Please contact with authorized dealer or manufacture.**



**Caution: Don't position the ME EQUIPMENT so that it is difficult to operate the disconnection device.**

 <p>1) Illumination part</p>	 <p>2) Base part</p>	 <p>3) head-rest Part</p>
 <p>4) Rail Cover</p>	 <p>5) Binocular Tube</p>	 <p>6) Focusing Test Rob</p>

 <p>7) Power box</p>	 <p>8) Worktop</p>	 <p>9) Input Power Cable</p>
 <p>10) Shaft part</p>	 <p>11) Brush</p>	 <p>12) Protection Cap</p>
 <p>13) Chin-rest Paper</p>	 <p>14) Mirror</p>	 <p>15) Spare Illumination Bulb</p>

### 3.1 Selecting voltage and fuse

1. Check the setting on the voltage selector located on the bottom of the power box. If it doesn't match with the input voltage, slide it to the proper position.
2. Open the fuse holder and take out the fuse, check and ensure that its rated value is corresponding to the mains voltage.

Specification of fuse : AC 120V T1.0 AL125V  
AC 230V T0.5 AL250V



**Caution:** Set the input voltage and frequency of instrument according to that of the mains

### 3.2 Assembling the worktop and Head-rest part

1. Assembling the work table or the motorized instrument table if you have ;
2. Assembling the Head-rest part.
  - a ) Put two cables through the hole on the worktop ;
  - b) Remove the two screws attached to the head-rest part with the worktop.

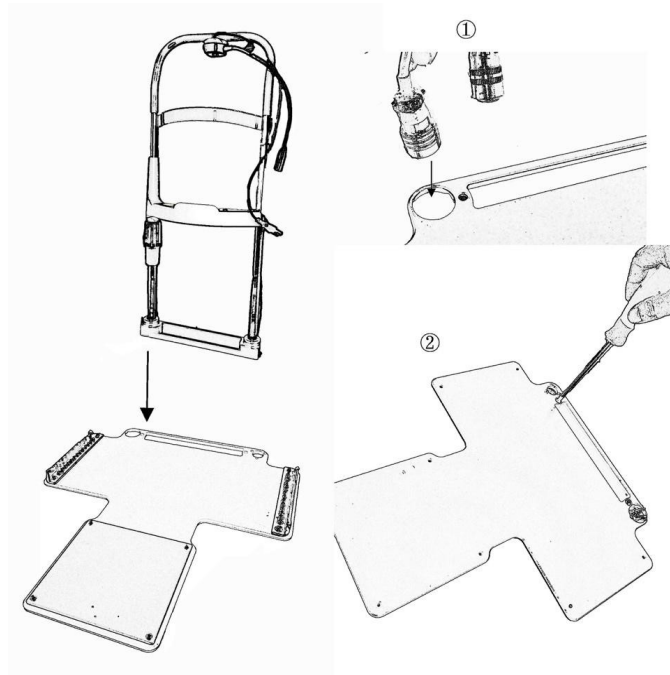

Fig 2

### 3.3 Assembling the Shaft part

As shown in the figure 3 ;

- 1 ) Put the Shaft pass through of the base part ;
- 2 ) Clamp the screw on the wheel.

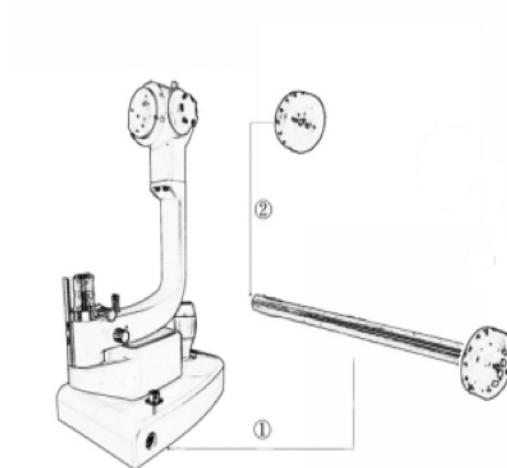

Fig 3



**Caution:** There is some oil on the Shaft pass, take care about assembly.

### 3.4 Assembling the base part and the rail covers

1. Place the wheels of both sides of the base on the rails on the worktop ;
2. Check whether the wheels can be rolled steadily on the rails.
3. Place the rail cover to the rail and retighten the previously removed screws.

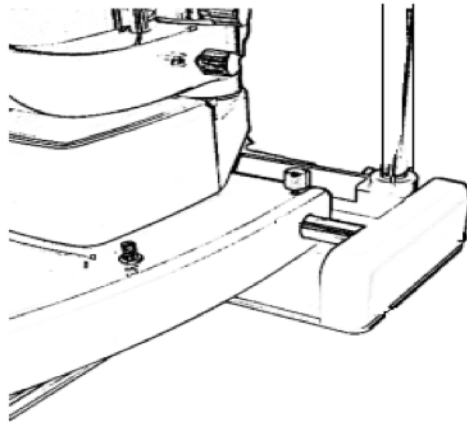

Fig 4

### 3.5 Assembling the binocular tube

Match the groove on the binocular tube with the pin on the slit lamp body.

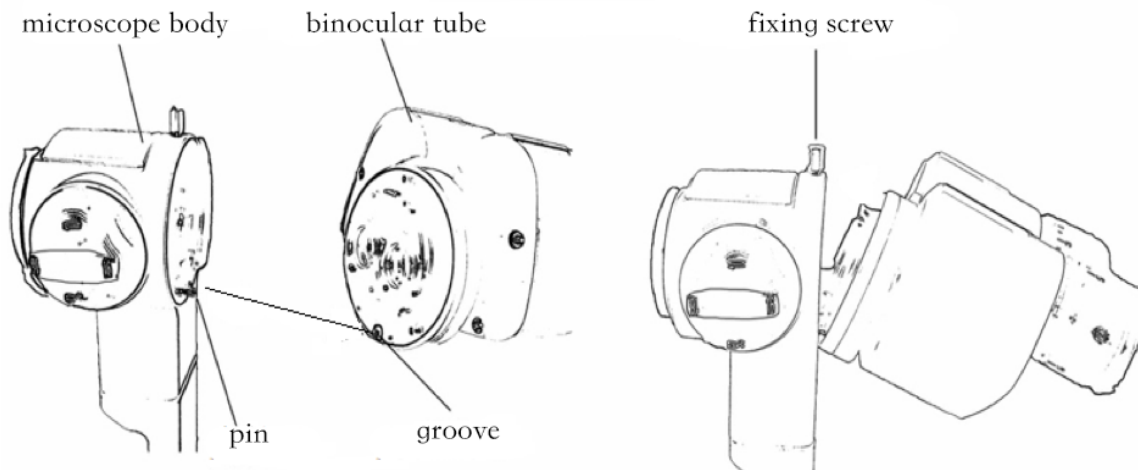

Fig 5

### 3.6 Assembling illumination part

As shown in the figure 6.1;

1. Rotate the brass shaft sleeve so that red mark is 30 to 90 degree from the limiting board.
2. Loosen the screw in the illumination arm with the screwdriver. Aim the assembly hole of the illumination arm at the brass shaft sleeve with care then put down, let the shaft keeping close to the bottom surface well and simultaneously the two red marks stretch in one line.
3. After the two red marks accurately aligned, retighten the screw.

### 3.7 Removing the illumination part shipping pad

As shown in the figure 6.2;

Remove the rubber band and gently pull the pad out

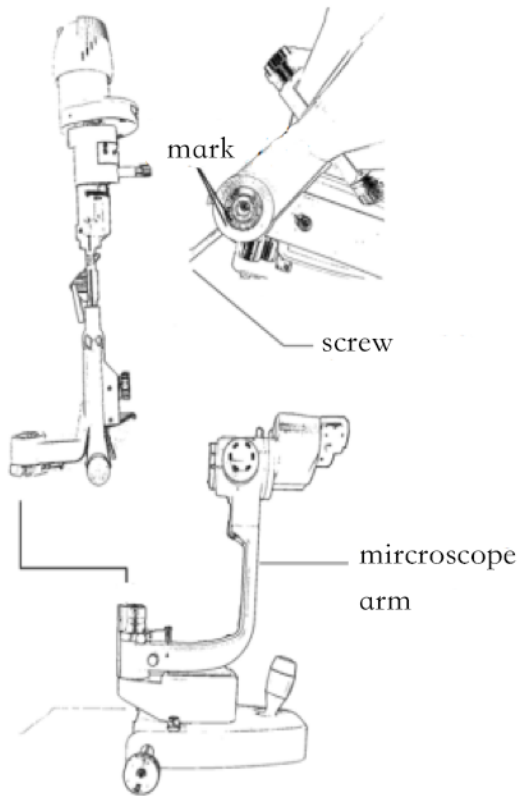

Fig 6.1

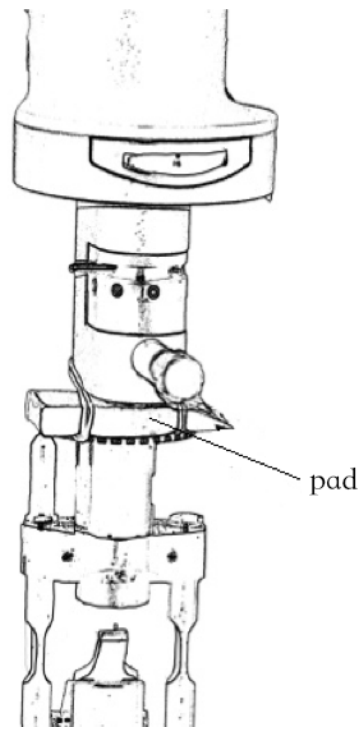

Fig 6.2

### 3.8 Connecting plug

1. Peel off the sticky tape attached to the lamp cap, which ensures that the cap is tightened to the lamp base during shipping.
2. Insert the lamp cable on the top of the headrest part into the socket of the lamp cap on the illumination part.
3. Connect the two plugs below the headrest part with the corresponding output socket of the power box.
4. Insert the plug of the input power cable into the input socket of the power box.
5. Remove the cable clips from the bottom of the work table with screw driver and wrap the output and input cables respectively.

### 3.9 Assembling the chin-rest paper

1. Pull out the two fixing pins from the chin-rest.
2. Get rid of the paper package and let the pins go through its holes.
3. Insert the fixing pins into the hole again.

### 3.10 Checking procedure after assembling

#### 1 Power plug

This instrument supplies a 3-wire cable. Please select a proper power socket as matched. Ensure that the instrument is grounded well.



**Caution:** Please use the special cable supplied with this instrument.

## 2 The power box and the illumination part

1. When the main power switch of the power box is placed at 'I', it turns on, and 'O' for turn off. The main power switch should be set at the 'O' position before connecting the input cable with the power socket.
2. Turn on the main power switch, and the pilot lamp will be lighted. Open the slit width control knob to examine the illumination.
3. Rotate the brightness control switch respectively from left to right and the brightness should be changed accordingly.
4. Check the fixation target device to confirm it is lighted
5. Check whether all those moveable parts such as aperture and slit height control knob, filter selection lever, and magnification changer lever etc. could be operated freely.
6. After examining, turn off the main power. Cover the instrument with the dust-proof cover after the lamp cap has been cool.

## 4 Operation procedures

### 4.1 Diopter compensation and pupil distance adjustment

#### 1) Use of the focusing test rod

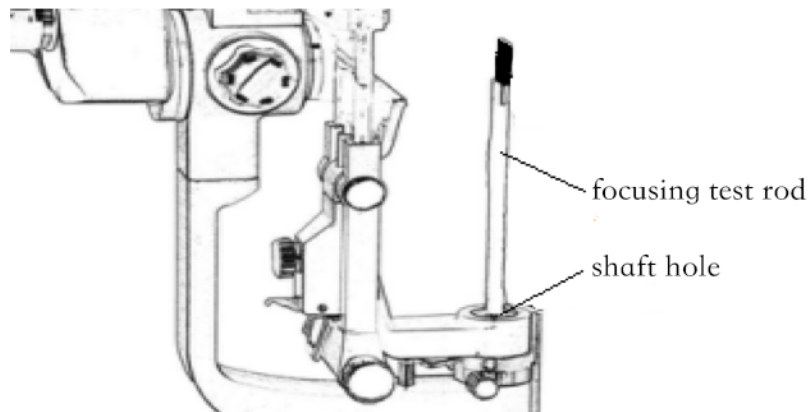

Fig 7

The rod is supplied as standard accessories for confirming the slit lamp's accurate adjustment. Insert it into the main shaft hole with the flat surface facing the objective lens the direction of the operator.



**Caution:** After adjusting, remember to take out the rod.

#### 2) Brightness adjustment

1. Switch on the main power switch and set the brightness control switch at middle position. Turn the slit width control knob to make the slit width to be 2~3mm.

#### 3) Diopter compensation

The focus of slit lamp is calibrated according to the emmetropia. If the operator is an ametropia, he should adjust the eyepiece diopter. One eyepiece with four short reticle lines that is usually placed at the right side helps to focus accurately when accessories being attached.

Suggest adjusting the diopter as following procedures:

1. Rotate the diopter adjustment ring counter clockwise down to the end.
2. Rotate the ring clockwise until a sharp slit image appears in the focusing text rod. At the time, it is also the clearest observation of the reticule in the eyepiece.
3. Adjust another eyepiece in the same procedure.
4. Record the diopter value on each eyepiece for future reference.

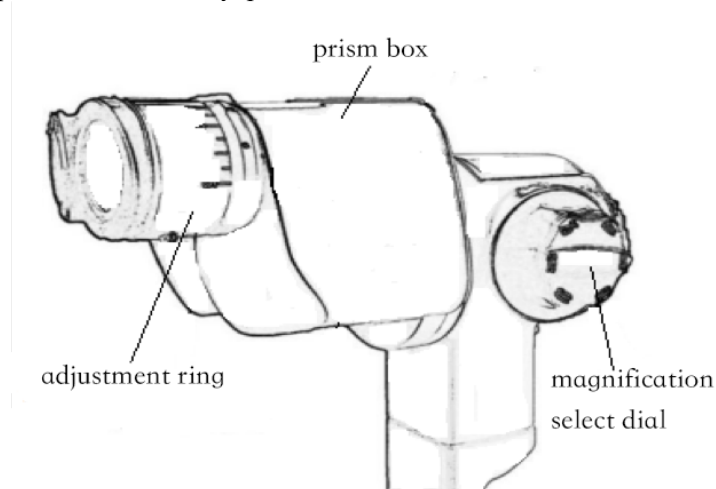

Fig 8

**4) Interpupillary distance adjustment**

Separate the prism box of the slit lamp with both hands to adjust the inter pupillary distance until both eyes could see the same image on the focusing test rod through the eyepieces, and at the same time a stereovision will be obtained.

**4.2 Patient position and fixation target**

**1) Positioning the patient's head**

Have the patient place his chin on the chin-rest and the forehead against the forehead-rest belt. Adjust the chin-rest elevation adjustment knob below the chin-rest until the patient's canthus aligns with the horizontal mark.

**2) Use of the fixation target**

For fixing the patient's eyesight, just make him look at the fixation target with eye not to be examined.

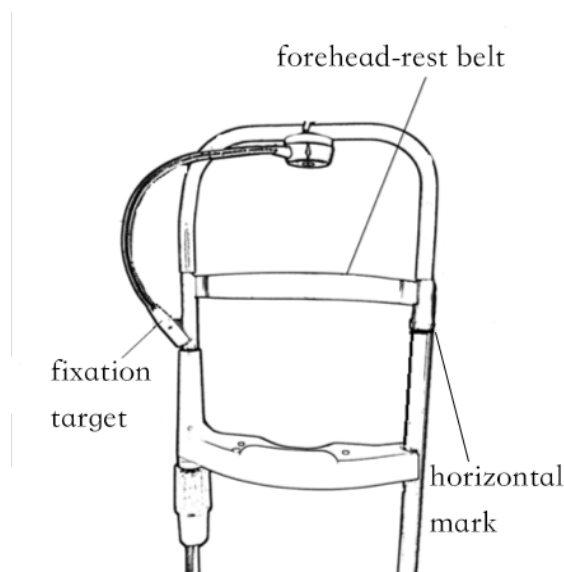

Fig 9

### 4.3 Base operation

#### 1) Horizontal rough adjustment

Keep the joystick upright and move the base to make the slit lamp move horizontally to aim at the object roughly.

#### 2) Vertical adjustment

Rotate the joystick to adjust the slit lamp's height until it aligns with the target. Turn the joystick clockwise to raise the slit lamp and counter clockwise to lower it.

#### 3) Horizontal fine adjustment

Tilt the joystick to make the slit lamp move slightly on the horizontal surface while watching through the eyepieces, tilt the joystick to aim accurately at the object for a sharp image.

#### 4) Locking the base

When finishing the adjustment, fasten the base locking screw to lock the base and prevent it from sliding.

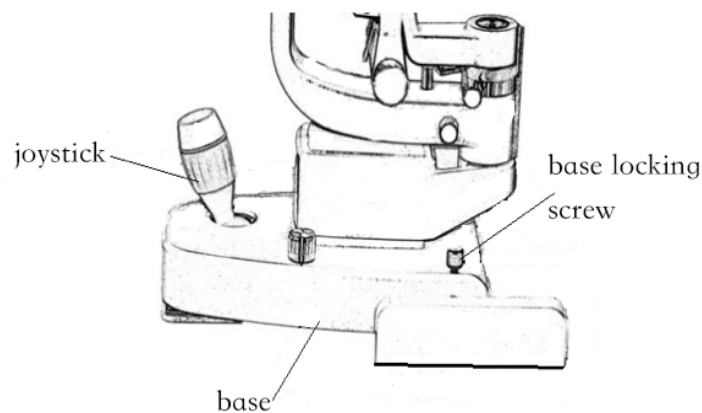

Fig 10

### 4.4 Operation illumination

#### 1) Changing the slit width

Turn the slit width control knob to change the slit width from 0mm to 14mm. The slit becomes a circle at 14mm. The scale on the knob indicates the width value approximately.

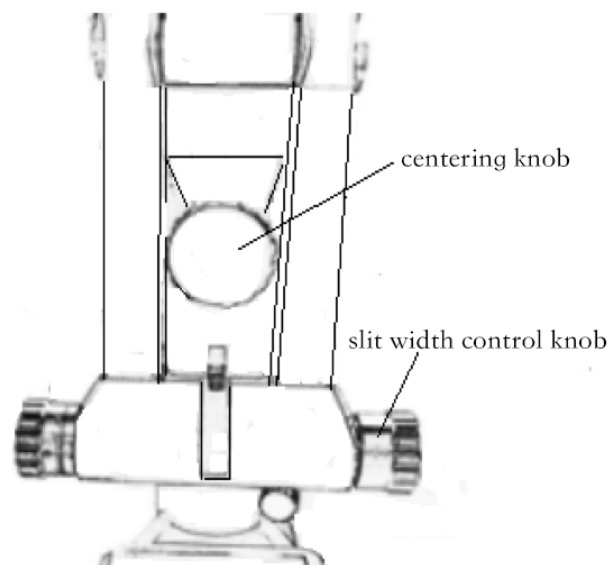

Fig 11

## 2) Changing the aperture and slit height

Turn the aperture and slit height control knob and 6 different circular beams of light are available at full aperture: (  $\varnothing 14$ 、 $\varnothing 10$ 、 $\varnothing 5$ 、 $\varnothing 2$ 、 $\varnothing 1$ 、 $\varnothing 0.2$  ) respectively. With a slit image, the slit height can be changed continuously from 1 to 14mm, which is indicated through the display window.

## 3) Rotating the slit image

Swing the aperture and slit height control knob horizontally to revolve the slit image at any angle in the vertical or horizontal direction. The angle of image rotation is indicated by the rotation angle scale with small division for  $5^\circ$  and big for  $10^\circ$ .

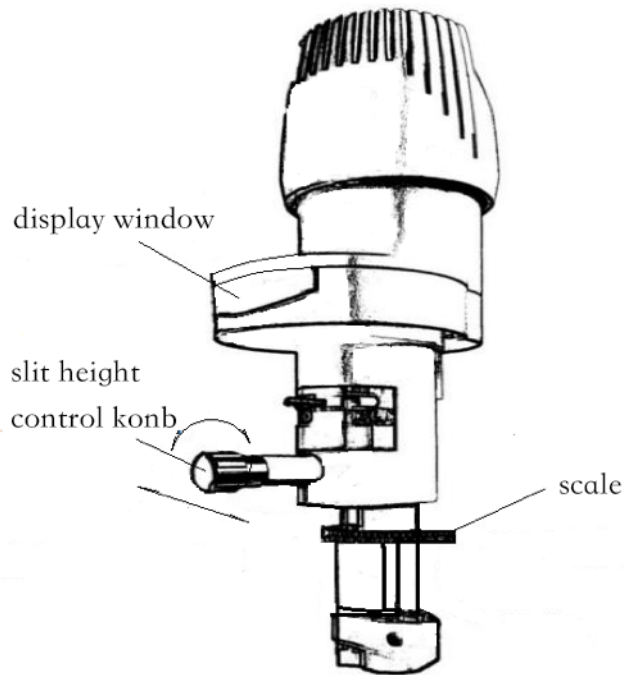

Fig 12

## 4) Decentring the illumination light

As shown in the Figure 11. Loosen the centering knob and swing the slit width control knob back and forth so the light spot moves away from the center of the slit lamp vision field. It is mainly used for indirect

retro-illumination examination. Fasten the centering knob and the slit light will return to the center of slit lamp vision field.

## 5) Oblique illumination

Oblique illumination is used for sectional or fundus examination using a contact lens. Press down the inclination lever so that the illumination part may incline to  $20^\circ$  , (  $5^\circ$  each division ) .

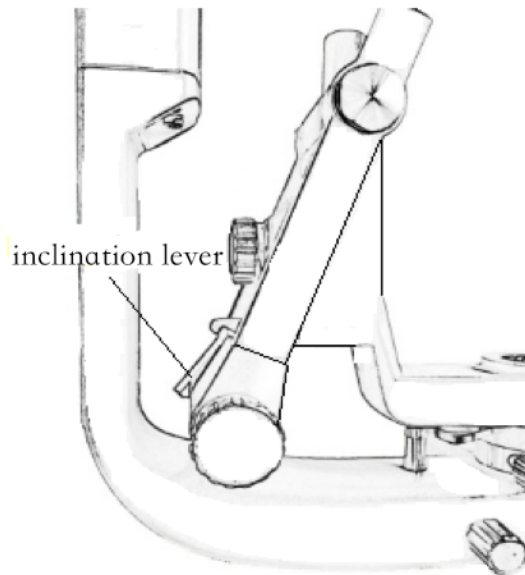



Fig 13

 **Caution:** Be careful since the illumination part may hit patient's head.

**6) Reflecting mirror**

Both short and long reflecting mirror are available. Use the long mirror in normal examination. When the angle between the illumination part and the slit lamp is within 3° to 10°, use the short mirror to avoid the image being obstructed. The short mirror is also used when the illumination part is inclined over 10°.

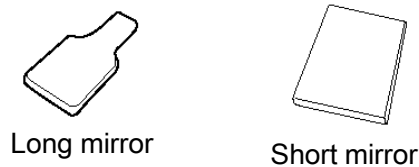

Fig 14

**7) Filter selection**

By shifting the filter selection lever four different filters can be inserted into the illumination pathway. Usually the heat absorption filter is used for patient comfort.

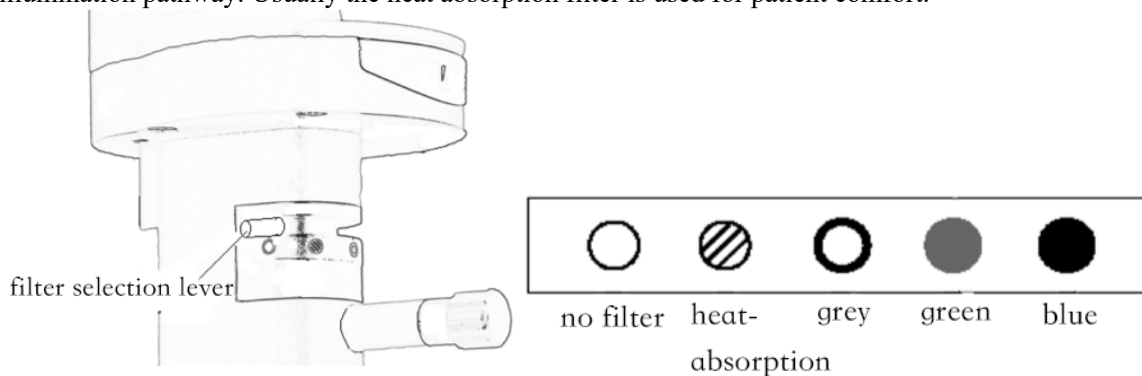

Fig 15

**8) Diffusion lens**

Turn the diffusion lens up when using it. The angle between the slit lamp arm and illumination unit should be about 30 degrees, otherwise the diffusion lens or illumination support shaft may shade some of the pictures. Set the slit at full aperture, otherwise the light intensity will be reduced. Turn it down after using.

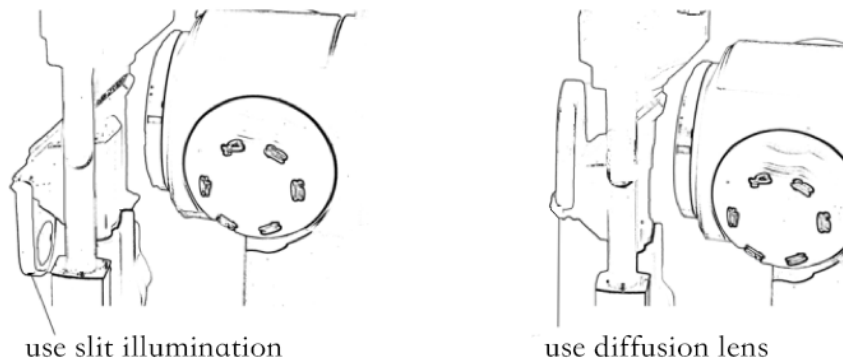

Fig 16

## 5 Maintenance

### 5.1 Replacing the illumination bulb



**Caution:** Treat the replaced waste materials as industrial rubbish. The bulb is very hot.

1. Turn the main power switch off.
2. Pull out the plug attached to the lamp house, turn the lamp cap counter clockwise and remove it from the illumination part.
3. Remove the lamp locking screw.
4. Replace the old bulb with a new one. The groove of bulb fixation disc should be aimed at the flange of lamp base.
5. Insert lamp plugs into the lamp feet, and screw up.

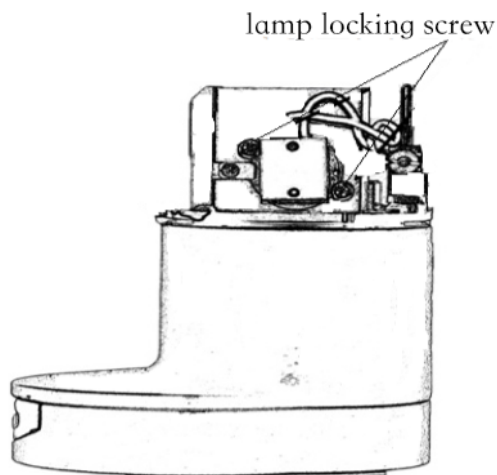

Fig 17

### 5.2 Replacing the reflecting mirror

1. Set the angle of slit lamp and illumination arm to exceed  $30^\circ$ .
2. Incline the illumination arm by more than  $10^\circ$ .
3. Remove the long mirror by holding the extended surface.
4. Insert new long or short reflecting mirror.
5. When replacing the short mirror, just push the bottom of the mirror by an object with sharp end.

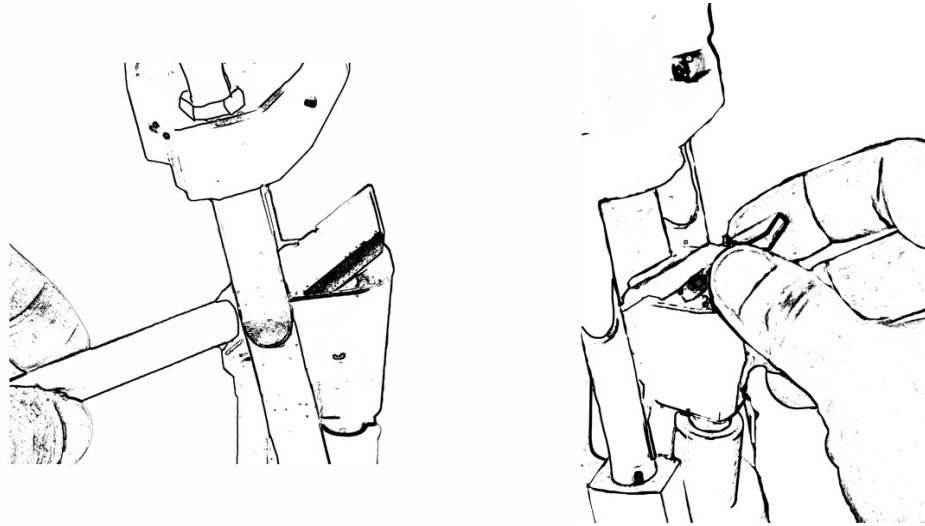

Fig 18

### 5.3 Replacing the fuse



**Caution:** Please select the fuse of the same type, specification and rate value.

1. Turn off the main power switch and remove the power cable from the outlet.
2. Pull the fuse holder out, and replace a new fuse.
3. Push the fuse holder in. The fuse specifications and rated values are as follows:

AC 120V T1.0 AL125V

AC 230V T0.5 AL250V

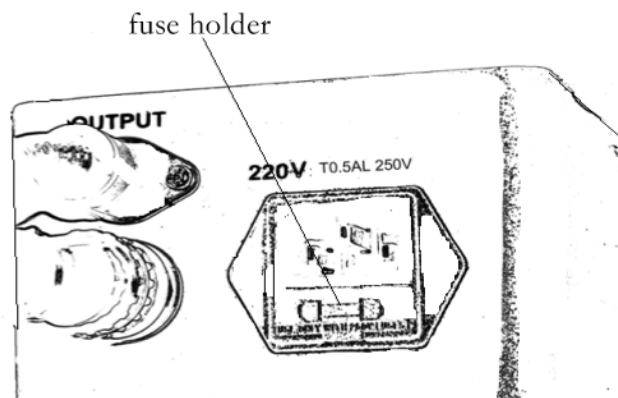

Fig 19



### 5.4 Replacing the chin-rest paper

When the paper is depleted, pull upward two fixing pins of the chin-rest and place a new package of paper, then fix the fixing pins again.



**Caution:** Recycle the product separate from other disposables.

## 5.5 Consumables

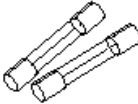
Part name	Outlook
Illumination bulb	
Long reflecting mirror	
Chin-rest paper	
Fuse: T1.0 AL 125V T0.5 AL 250V	

## 5.6 Adjusting the tightness of the slit width knob

If the slit width control knob is too loose, the slit width may be out of control.

1. Loosen the screw on the right knob with the Allen wrench.
2. Hold the left knob firmly with one hand, while the other hand rotates the right knob clockwise to adjust its tightness.
3. When it is appropriate, fasten the screw of the right knob firmly again.

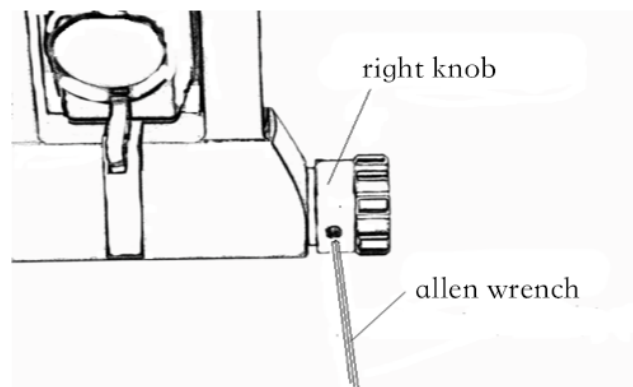

Fig 20

## 5.7 Cleaning

1. Cleaning the lens and mirror

If any dust stick on the lenses or reflecting mirrors, brush them with the brush. In case any dust still remains, wipe it off with soft cotton dipped with absolute alcohol.



**Caution:** Never scratch with fingers or any other hard materials.

2. Cleaning the slide plate, rails and shaft

If the slide plate, rails and shaft are dirty, the vertical and horizontal movement will be unsteady. Wipe them with clean soft cloth.

3. Cleaning and sterilizing the plastic parts

Clean the plastic parts such as chin-rest bracket, forehead-rest belt with soft cloth dipped with soluble detergent or water, sterilize with medicinal alcohol.

## 6 Trouble shooting guide

In case there is any trouble, please check according to the following table for reference. If it still cannot work, please contact our Repair Department or an authorized distributor.

Trouble	Possible cause	Remedy
NO illumination	The cable isn't connected correctly with the power socket.	Connect the power cable correctly.
	The main power switch is on 'O' position.	Place the switch on 'I' position.
	The plug on the power box is loose.	Insert the plug firmly.
	The plug on the lamp cap is loose.	Insert the plug firmly.
	The plug of brightness control connector is not connected.	Insert the plug of brightness control connector.
	The bulb has burnt out.	Change the bulb.
	The fuse has blown.	Change the fuse
Slit is too dark	The bulb is not assembled properly.	Assemble the bulb properly
	The filter lever is in the middle position or in the position of gray filter.	Set the filter lever to the correct position.
	Voltage selector is wrongly set.	Set the voltage selector correctly
	The coat of the reflecting mirror is oxidized.	Change the reflecting mirror.
	Too much dust on the reflecting surface.	Clean the surface with brush.
Fuse has blown	Voltage selector is wrongly set.	Set the voltage selector correctly
	The fuse doesn't comply with the specification.	Replace it with a suitable fuse.
Slit width closes automatically	The slit width control knob is too loose.	Adjust the tightness of the control knob.
Fixation bulb is off	The output plug is loose.	Insert the output plug firmly.

## 7 Repair

We will supply the circuit diagram of the instrument, electric component list, drawing annotation and calibration details according to the customer's need for repair.

If there is any need for inquiry of relative information and relative service or some questions, please contact with us directly or authorized distributors.

## 8. Technical specification

<b>Microscopes</b>		
Type	Galileo magnification changer with converging	
Model of magnifying	5 steps by drum rotation	
Eyepiece	12.5x	
Total magnification rate	6.2x ,10x, 16x, 25x, 40x	
Field-of-view	Ø33mm, Ø22.5mm, Ø14mm,Ø8.8mm, Ø5.5mm	
Range of P.D adjustment	-5D ~ +5D	
Diopter adjustment	55mm~ 75mm	
<b>Illumination</b>		
Aperture diameter	Ø14mm, Ø10mm, Ø5mm, Ø2mm, Ø1mm, Ø0.2mm	
Slit width	continuous from 0mm to 14mm ( become a circle at 14mm )	
Slit height	continuous from 1mm~14mm	
Slit projection magnification	1x	
Slit angle	0° to 180°continuously adjustable from vertical to horizontal	
Filter piece	Heat-absorbing, gray, red-free, blue	
Slit inclination	5°, 10°, 15°, 20° four steps	
Illumination bulb	12V 30W halogen bulb	
<b>Movement base</b>		
Fore and back movement	100mm	
Left and right movement	105mm	
Fine movement	15mm	
Vertical movement	30mm	
<b>Chin-rest parts</b>		
Vertical movement	80mm	
Fixation target	Red LED	
Power source		
Rated voltage	AC230V±10%/50Hz, AC120V±10%/60Hz	
Input voltage	58VA	
Fuse	AC 120V T1.0 AL125V AC 230V T0.5 AL250V	
Electrical Safety Standard	IEC60601-1 Class 1 Type B	
<b>Dimension and weight</b>		
Packing	600mm×450mm×330mm	
Total weight	22Kg	
Net weight	20Kg	
Conditions for use	Environment temperature	+10°C~+40°C
	relative humidity	30%~75%
	atmospheric pressure	700 hPa~1060 hPa
Shipping and Storage	Environment temperature	-40°C~+55°C
	relative humidity	10%~80%
	atmospheric pressure	500 hPa~1060 hPa

## 9. EMC (electromagnetic compatibility)

When using the device, the EMC precautions specified below must be observed.

- Only use spare parts approved for this device.
- Do not use any portable or mobile RF communication equipment in the vicinity of the device as this may impair the device's function.
- Do not use a mobile phone in the vicinity of the equipment because the radio interference can cause the equipment to malfunction. The effects of radio interference on medical equipment depend on a number of various factors and are therefore entirely unforeseeable.
- Please note the EMC guidelines on the following pages.



**Warning: The slit lamp should not be used adjacent to or stacked with other equipment and that if adjacent or stacked use is necessary, the ME EQUIPMENT or MESYSTEM should be observed to verify normal operation in the configuration in which it will be use.**



**Warning: Use of ACCESSORIES, transducers and cables other than those specified, with the exception of transducers and cables sold by the MANUFACTURER of the slit lamp as replacement parts for internal components, may result in increased EMISSIONS or decreased IMMUNITY of the slit lamp.**

### Electromagnetic interference

Guidance and manufacturer's declaration – electromagnetic emissions		
The slit lamp is intended for use in the electromagnetic environment specified below. The customer or the user of the slit lamp should assure that it is used in such an environment.		
Emissions test	Compliance	Electromagnetic environment – guidance
RF emissions CISPR 11	Group 1	The slit lamp uses RF energy only for its internal function. Therefore, its RF emissions are very low and are not likely to cause any interference in nearby electronic equipment.
RF emissions CISPR 11	Class B	The slit lamp is suitable for use in all establishments, including domestic establishments and those directly connected to the public low-voltage power supply network that supplies buildings used for domestic purposes.
Harmonic emissions IEV 61000-3-2	Class A	
Voltage fluctuations/ flicker emissions IEC 61000-3-3	Complies	

### Electromagnetic immunity for ME equipment and ME systems

Guidance and manufacturer's declaration – electromagnetic immunity			
The slit lamp is intended for use in the electromagnetic environment specified below. The customer or the user of the slit lamp should assure that it is used in such an environment.			
IMMUNITY test	IEC 60601 test level	Compliance level	Electromagnetic environment – guidance
Electrostatic discharge (ESD) IEC 61000-4-2	± 6 kV contact ± 8 kV air	± 6 kV contact ± 8 kV air	Floors should be wood, concrete or ceramic tile. If floors are covered with synthetic material, the relative humidity should be at least 30 %.
Electrical fast transient/burst IEC 61000-4-4	± 2 kV for power supply lines ± 1 kV for input/output lines	± 2 kV for power supply lines ± 1 kV for input/output lines	Mains power quality should be that of a typical commercial or hospital environment.
Surge IEC 61000-4-5	± 1 kV line(s) to line(s) ± 2 kV line(s) to earth	± 1 kV line(s) to line(s) ± 2 kV line(s) to earth	Mains power quality should be that of a typical commercial or hospital environment.
Voltage dips, short interruptions and voltage variations on power supply input lines IEC 61000-4-11	<5 % $U_T$ (>95 % dip in $U_T$ ) for 0,5 cycle 40 % $U_T$ (60 % dip in $U_T$ ) for 5 cycles 70 % $U_T$ (30 % dip in $U_T$ ) for 25 cycles <5 % $U_T$ (>95 % dip in $U_T$ ) for 5 s	<5 % $U_T$ (>95 % dip in $U_T$ ) for 0,5 cycle 40 % $U_T$ (60 % dip in $U_T$ ) for 5 cycles 70 % $U_T$ (30 % dip in $U_T$ ) for 25 cycles <5 % $U_T$ (>95 % dip in $U_T$ ) for 5 s	Mains power quality should be that of a typical commercial or hospital environment. If the user of the slit lamp requires continued operation during power mains interruptions, it is recommended that the slit lamp be powered from an uninterruptible Power supply or a battery.
Power frequency (50/60 Hz) magnetic field IEC 61000-4-8	3A/m	3A/m	Power frequency magnetic fields should be at levels characteristic of a typical location in a typical commercial or hospital environment.
NOTE $U_T$ is the a.c. mains voltage prior to application of the test level.			

**Electromagnetic immunity for non-life-supporting ME equipment and ME systems**

Guidance and manufacturer's declaration – electromagnetic immunity			
The slit lamp is intended for use in the electromagnetic environment specified below. The customer or the user of the slit lamp should assure that it is used in such an environment.			
IMMUNITY test	IEC 60601 test level	Compliance level	Electromagnetic environment – guidance
<p>Conducted RF EN 61000-4-6</p> <p>Radiated RF IEC 61000-4-3</p>	<p>3 Vrms 150 kHz~80 MHz</p> <p>3 V/m 80 MHz~2.5 GHz</p>	<p>3 Vrms</p> <p>3V/m</p>	<p>Portable and mobile RF communications equipment should be used no closer to any part of the slit lamp, including cables, than the recommended separation distance calculated from the equation applicable to the frequency of the transmitter.</p> <p>Recommended separation distance</p> $d=1.2 \sqrt{P}$ $d=1.2 \sqrt{P} \quad 80 \text{ MHz} \sim 800 \text{ MHz}$ $d=2.3 \sqrt{P} \quad 800 \text{ MHz} \sim 2.5 \text{ GHz}$ <p>where P is the output power rating of the transmitter in watts (W) according to the transmitter manufacturer's specifications and d is the recommended safety distance in meters (m).</p> <p>Field strengths from stationary RF transmitters, as determined by a site survey<sup>a</sup>, should be less than the compliance level in all frequency ranges.<sup>b</sup></p> <p>Interference may occur in the vicinity of equipment marked with the following symbol:</p> 
NOTE 1 At 80 MHz and 800 MHz, the higher frequency range applies.			
NOTE 2 These guidelines may not apply in all situations. Electromagnetic propagation is affected by absorption and reflection from structures, objects and people.			
<p>a Field strengths of stationary transmitters such as base stations for mobile telephones and mobile land radio equipment, amateur radio stations, AM and FM radio broadcast and TV broadcast transmitters cannot be theoretically predicted accurately. To assess the electromagnetic environment with respect to stationary RF transmitters, a site study of the electromagnetic phenomena should be considered. If the measured field strength in the location where the device is used exceeds the compliance levels indicated above, the device should be monitored to verify normal operation. If abnormal performance is observed, additional measures may be necessary, such as re-orienting or relocating the ME equipment or ME system.</p> <p>b Field strengths should be less than 3 V/m over the frequency range from 150 kHz to 80 MHz.</p>			