

CCD-8000C Defibrillator Monitor
User's Manual

Preface

Thank you for using defi- Monitor.

In order to enable you to skillfully operate defi- Monitor as soon as possible, we provide this user's manual with delivery. When you install and use this instrument for the first time, it is imperative that you read carefully all the information that accompanies this instrument.

Based on the need to improve the performance and reliability of the parts and the whole instrument, we sometimes will make some amendments to the instrument (including the hardware and software). As a result, there might be cases of discrepancies between the manual and the actual situation of products. When such discrepancies occur, we will try our best to amend or add materials. Your comments and suggestions are welcome.

Statement

This manual contains exclusive information protected by copyright laws and we reserve its copyright. Without written approval of manufacturer no parts of this manual shall be photocopied, Xeroxed or translated into other languages.

The contents and version contained in this manual are subject to amendments without notification.

The version number of this manual: A2

Liabilities of the Manufacturer

Only under the following circumstances will manufacturer be responsible for the safety, reliability and performance of the instrument.

⇒ All the installation, expansion, readjustment, renovation or repairs are conducted by the personnel certified by manufacturer

⇒ The electrical safety status at the installation site of the instrument conforms to the national standards;

⇒ The instrument is used in accordance with the operation procedures.

CONTENTS

CHAPTER 1 GENERAL INTRODUCTION.....	1
1.1 INTENDED USE.....	1
1.2 ABOUT THIS MANUAL.....	1
1.3 BRIEF INTRODUCTION TO THE MONITOR PART.....	3
CHAPTER 2 IMPORTANT SAFETY NOTES.....	8
2.1 GENERAL SAFETY.....	8
2.2 SOME IMPORTANT NOTES FOR SAFETY.....	10
2.3 CLASSIFICATIONS.....	12
2.4 SAFE OPERATING AND HANDLING CONDITIONS.....	12
CHAPTER 3 GETTING STARTED.....	13
3.1 OPEN THE PACKAGE AND CHECK.....	13
3.2 CONNECT POWER.....	13
3.3 CONNECT TO THE CENTRAL MONITOR SYSTEM.....	16
3.4 POWER ON THE MONITOR.....	16
3.5 CONNECT PATIENT SENSORS.....	16
CHAPTER 4 OPERATION INSTRUCTIONS.....	18
4.1 MAIN MENU.....	18
4.2 WORK SCREEN.....	18
4.3 SETUP VOLUME.....	19
4.4 SETUP WAVE SWEEP SPEED.....	20
4.5 SETUP PATIENT INFORMATION.....	20
4.6 SYSTEM SETUP.....	20
4.7 SETUP RECORDER.....	23
4.8 RESTORE DEFAULT SYSTEM SETUP.....	24
4.9 DISPLAY OF TREND.....	24
4.10 DISPLAY INFORMATION ON THE SCREEN.....	25

CHAPTER 5 PARAMETERS MEASUREMENT.....	27
5.1 MEASUREMENT OF ECG/HR.....	27
5.2 MEASUREMENT OF RESP.....	34
5.3 MEASUREMENT OF SPO₂/PULSE.....	36
5.4 MEASUREMENT OF TEMP.....	40
5.5 MEASUREMENT OF NIBP.....	43
CHAPTER 6 ALARM.....	51
6.1 ALARM PRIORITY.....	51
6.2 ALARM MODES.....	51
6.3 ALARM SETUP.....	52
6.4 ALARM STATE ICON.....	53
6.5 SILENCE/ALARM PAUSED.....	54
6.6 PARAMETER ALARM.....	54
6.7 WHEN AN ALARM OCCURS.....	55
6.8 ALARM DESCRIPTION AND PROMPT.....	55
CHAPTER 7 RECORDING.....	60
CHAPTER 8 THE MAINTENANCE AND CLEANING.....	62
8.1 SYSTEM CHECK.....	62
8.2 BATTERY MAINTENANCE.....	63
8.3 GENERAL CLEANING.....	64
8.4 CLEANING AGENTS.....	64
8.5 STERILIZATION.....	65
8.6 DISINFECTION.....	66
BRIEF INTRODUCTION TO THE DEFIBRILLATOR PART.....	67
APPENDIX.....	71

Chapter 1 General Introduction

1.1 Intended use

Defi-Monitor is used to monitor patient's physiological parameters such as ECG、RESP、SpO₂、NIBP、DEFI and TEMP continuously. It is intended to be used in various hospital rooms such as Coronary Care Unit, Intensive Care Unit, Neonatal Intensive Care Unit and Operating Room to provide additional information to medical and nursing staff about the physiological condition of the patient.

It is not intended to be used in outdoor transport applications.

1.2 About this Manual

This user's manual consists of the following chapters:

Chapter 1 gives an introduction to the content and the specific signs of this manual, the main features and appearance of the monitor, the basic operations of various buttons, the meanings of the signs on the monitor.

Chapter 2 gives important safety notes **Please do read this chapter before using the monitor!**

Chapter 3 gives an introduction to the preparatory steps before using the monitor.

Chapter 4 provides general operation instruction for the monitor, including illustrations of the screen display, normal selection for soft button on screen, details for entry of patient data and trend maps, also.

Chapter 5 gives details of specific parameter measurement, preparatory steps, cables or probes connection, setup of parameters, maintenance and cleaning of equipments and sensors.

Chapter 6 gives detailed description of system alarm, including level and mode of alarm, default setting and changing procedure of alarm parameters, prompt of specific alarms, and the general operation to carry out when an alarm occurs.

Chapter 7 gives detailed description of record function.

Chapter 8 gives general maintenance and cleaning methods of the monitor and its parts.

Signs in this manual:



Warning: Indicates a potential hazard or unsafe practice which, if not avoided, could result in death or serious injury.



Caution: Indicates a potential hazard or unsafe practice which, if not avoid, could result in minor personal injury or product/property damage.



Note: Provides application tips or other useful information to assure that you get the most from your equipment.



Note: This user manual introduced the product that with full configuration. Some functions of the product you bought may be has not provided.

1.3 Brief Introduction to the Monitor Part

The monitor has features as follows:

- ⇒ Multiple measuring functions include 3-lead, 7-lead ECG/HR, RESP, SpO₂/Pulse, NIBP.
- ⇒ Complete built-in module design ensures stable and reliable performance
- ⇒ Can store the trend data for 72 hours and has the function of displaying trend data and trend maps
- ⇒ Function of NIBP measurement reviewing, can store 600 pieces of NIBP measurement data
- ⇒ Optional built-in recorder supports real-time recording, present screen printout and trigger printout by alarm
- ⇒ Parameter display with big character
- ⇒ 7" color high brightness TFT LCD monitor
- ⇒ Portable design, stylish and convenient
- ⇒ Rechargeable maintenance-free battery, can continue working when AC power is off
- ⇒ Nurse call function guarantee patient alarm draws enough attention
- ⇒ Can be connected with the central station to realize centralized monitoring
- ⇒ Is resistant to high-frequency electrostatic and is protected against defibrillation effects

1.4.1 The Front Appearance



1. energy selector to select the energy of the heart defibrillating treatment

2. AC power indicator lamp

It is turned on when AC power is connected.

It is turned out when then AC power is not connected.

3.  monitor Power switch

4. Battery charging indicator lamp

It is illumined when the battery is being charged or using battery only.

It goes out when the battery is fully charged or no battery in monitor.

5.  Press this key to open the menu dialog when there is no dialog on the screen, otherwise, pressing this key can close the dialog on the screen.

6.  Press this key less than 2 seconds can make the monitor alarm paused

or cancel the pause.

Pressing this key over 2 seconds can silence the monitor's audio system or cancel the silence.

7. Trim Knob

The Trim Knob is used for:

Turn left or turn right to move the cursor.

Press down to perform an operation, such as open the menu dialog or selects one option.

8.  Press this key to freeze or defreeze the wave display on screen.

9.  Press this key to start or stop the NIBP measurement.

10.  Press this key to start or stop the real-time recording.

11. ECG socket

12. SpO₂ socket

13. NIBP cuff connector

14. TEMP1 socket

Warning: The sensor cable sockets on the monitor can only be connected with the sensor cables supplied with this instrument and no other cables shall be used.

1.4.2 The Back Appearance



1. AC input socket

! **Caution: The AC input at the back panel of the Monitor should be connected with the 100V~240V AC Power by electrical wires supplied with this instrument.**





2. Potential equalization conductor terminal



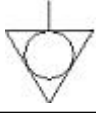

Base on the requirements of safety and anti-interference, the monitor must be connected with potential equalization system individual. Connect the Potential equalization conductor terminal to the potential equalization system with the green and yellow potential equalization cable. If the protection earth system is damaged, the potential equalization system can take on the safety function of protection earth conductor.

3. FUSE

Fuse specs: T3.0AL250V $\Phi 5 \times 20$ mm

1.4.3 Notes on the signs on the monitor

Signs	Notes on the signs
	<p>Defibrillator-proof type CF equipment (Refer to IEC 60601-2-27)</p> <p>The unit displaying this symbol contains an F-Type isolated (floating) applied part providing a high degree of protection against shock, and is defibrillator-proof.</p>
	<p>Attention! Please refer to the document supplied with this instrument (this manual)!</p>
	<p>Potential equalization conductor terminal</p>
	<p>Dangerous voltage</p>
	<p>AC/Battery power indicator</p>

	Battery charge indicator
	Non-ionizing radiation
	Auxiliary output
ECG	Short for “Electrocardiogram”.
SpO₂	Short for “Pulse Oxygen Saturation”
TEMP 1	Short for “Temperature” channel 1
TEMP 2	Short for “Temperature” channel 2
NIBP	Short for “Non-invasive Blood Pressure”
RESP	Short for “Respiration”
	Symbol for the marking of electrical and electronics devices according to Directive 2002/96/EC. The device, accessories and the packaging have to be disposed of waste correctly at the end of the usage. Please follow Local Ordinances or Regulations for disposal.

Chapter 2 Important Safety Notes



Warning: PACEMAKER PATIENTS. Rate meters may continue to count the pacemaker rate during occurrences of cardiac arrest or some arrhythmias. Do not rely entirely upon rate meter ALARMS. Keep pacemaker patients under close surveillance. See this manual for disclosure of the pacemaker pulse rejection capability of this instrument.



Warning: Only trained doctors and nurses can use the device.



Warning: The Monitor is not a therapeutic instrument nor is it a device that can be used at home.

2.1 General Safety

1. Safety precautions for safe installation

⇒ The AC input socket of the monitor can be connected to the electrical wires and common electrical wire can be used.

⇒ Only the power supply type of AC 100V~240V 50/60Hz specified by the Monitor can be used.

⇒ Connect the electrical wire to a properly grounded socket. Avoid putting the socket used for it in the same loop of such devices as the air conditioners, which regularly switch between ON and OFF.

⇒ Avoid putting the monitor in the locations where it easily shakes or wobbles.

⇒ Enough room shall be left around the monitor so as to guarantee normal ventilation.

⇒ Make sure the ambient temperature and humidity are stable and avoid the occurrence of condensation in the work process of the monitor.



Warning: Never install the monitor in an environment where flammable anesthetic gas is present.

2. The Monitor conforms to the safety requirements of IEC 601-1:1988. The Monitor is protected against defibrillation effects.

3. Notes on signs related to safety



Defibrillator-proof type CF equipment (refer to IEC 60601-2-27)

The unit displaying this symbol contains an F-Type isolated (floating) applied part providing a high degree of protection against shock, and is defibrillator-proof.

The type CF applied parts provide a higher degree of protection against electric shock than that provided by type BF applied parts.



Attention! Please refer to the documents accompanying this monitor (this manual)!

4. When a defibrillator is applied on a patient, the monitor may have transient disorders in the display of waveforms. If the electrodes are used and placed properly, the display of the monitor will be restored within 10 seconds. During defibrillation, please note to remove the electrode of chest lead and move the electrode of limb lead to the side of the limb. The electrode of the defibrillator should not come into direct contact with the monitoring electrodes. Please ensure the monitor is reliably grounded and the electrodes used repeatedly should be kept clean.



Warning: When conducting defibrillation, do not come into contact with the patient, the bed and the monitor. Otherwise serious injury or death could be resulted in.

5. To guarantee the safe operation of the monitor, the Monitor is provided with various replaceable parts, accessories and consuming materials (such as sensors and their cables, electrode pads). Please use the products provided or designated by the manufacturer.

6. The Monitor only guarantees its safety and accuracy under the condition that it is connected to the devices provided or designated by manufacturer. If the monitor is connected to other undesigned electrical equipment or devices, safety hazards may occur for causes such as the cumulating of the leakage current.

7. To guarantee the normal and safe operation of this monitor, a preventive check and maintenance should be conducted for the monitor and its parts every 6-12 months (including performance check and safety check) to verify the instrument can work in a

safe and proper condition and it is safe to the medical personnel and the patient and has met the accuracy required by clinical use.

! **Caution: The Monitor does not contain any parts for self-repair by users. The repair of the instrument must be conducted by the technical personnel been authorized by manufacturer.**

2.2 Some important notes for safety

PATIENT NUMBER

The Monitor can only be applied to one patient at one time.

INTERFERENCE

Do not use cellular phone in the vicinity of this equipment. High level of electromagnetic radiation emitted from such devices may result in strong interference with the monitor performance.

ACCIDENTAL SPILLS

To avoid electric shock or device malfunction, liquids must not be allowed to enter the device. If liquids have entered the device, take it out of service and have it checked by a service technician before it is used again.

ACCURACY

If the accuracy of any value displayed on the monitor or printed on a printout paper is questionable, determine the patient's vital signs by alternative means. Verify that all equipment is working correctly.

ALARMS

Do not rely exclusively on the audible alarm system for patient monitoring. Adjustment of alarm volume to a low level or off during patient monitoring may result in a hazard to the patient. Remember that the most reliable method of patient monitoring combines close personal surveillance and correct operation of monitoring equipment.

The functions of the alarm system for monitoring the patient must be verified at regular intervals.

BEFORE USE

Before putting the system into operation, please visually inspect all connecting cables for signs of damage. Damaged cables and connectors must be replaced immediately.

Before using the system, the operator must verify that it is in correct working order and operating condition.

Periodically, and whenever the integrity of the product is in doubt, test all functions.

CABLES

Route all cables away from patient's throat to avoid possible strangulation.

DISCHARGE TO CLEAR PATIENT DATA

When monitoring a new patient, you must clear all previous patient data from the system. To accomplish this, shut down the device, then turn on it.

DISPOSAL OF PACKAGE

Dispose of the packaging material, please observe the applicable waste control regulations and keep it out of children's reach.

EXPLOSION HAZARD

Do not use this equipment in the presence of flammable anesthetics, vapors or liquids.

LEAKAGE CURRENT TEST

When interfacing with other equipment, a test for leakage current must be performed by qualified biomedical engineering personnel before using with patients.

BATTERY POWER

The device is equipped with a battery pack. The battery discharges even when the device is not in use. Store the device with a fully charged battery and take out the battery, so that the service life of the battery will not be shortened.

DISPOSAL OF ACCESSORIES AND DEVICE

Disposable devices are intended for single use only. They should not be reused as performance could degrade or contamination could occur.

The service life of this monitor is five years. At the end of its service life, the product described in this manual, as well as its accessories, must be disposed of in compliance with the guidelines regulating the disposal of such products. If you have questions concerning disposal of products, please contact us.

EMC

Magnetic and electrical fields are capable of interfering with the proper performance of the device. For this reason, make sure that all external devices operated in the vicinity of the monitor comply with the relevant EMC requirements. X-ray equipment or MRI devices are a possible source of interference as they may emit higher levels of electromagnetic radiation. Also, keep cellular phones or other telecommunication equipment away from the monitor.

INSTRUCTION FOR USE

For continuous safe use of this equipment, it is necessary that listed instructions were followed. However, instructions listed in this manual in no way can supersede established medical practices concerning patient care.

LOSS OF DATA

Should the monitor at any time temporarily lose patient data, close patient observation or alternative monitoring devices should be used until monitor function is restored.

If the monitor does not automatically resume operation within 60 seconds, restart the monitor using the power on/off switch. Once monitoring is restored, you should verify correct monitoring state and alarm function.

2.3 Classifications

The Monitor is classified, according to IEC601-1: 1988 as:

Type of protection against electric shock:	I
Degree of protection against electric shock:	CF: ECG, Temp, RESP, NIBP, SpO ₂
Degree of protection against harmful ingress of water:	Ordinary Equipment (enclosed equipment without protection against ingress of water)
Degree of safety of application in the presence of a flammable anesthetic-mixture with air or with oxygen or nitrous oxide:	Not suitable
Mode of operation:	Continuous operation

I: Class I equipment

CF: Type CF applied part

Not suitable: Equipment not suitable for use in the presence of flammable anesthetic mixture with air or with oxygen or nitrous oxide.

2.4 Safe Operating and Handling Conditions

Method(s) of sterilization or disinfection recommended by the manufacturer:	Sterilization: not applicable Disinfection: See “The Maintenance and Cleaning of the System->General Cleaning”
Electromagnetic interference	No cellular telephone nearby
Electro surgical interference damage	No damage
Diathermy instruments influence	Displayed values and prints may be disturbed or erroneous during diathermy.
Defibrillation shocks	The Monitor specifications fulfill the requirements of IEC 601-1, IEC 60601-2-27, IEC 60601-2-49.
Auxiliary outputs	The system must fulfill the requirements of standard IEC 60601-1-1.

Chapter 3 Getting Started

3.1 Open the Package and Check

- ⇒ Unpack the packaging case

Open the packaging case and the accessory box, accessories include electrical wire, various patient sensors and user's manual (this manual), warranty card, certificate and particular paper and the foam case contains the monitor.

- ⇒ Remove the monitor and accessories

! **Caution: please place the monitor on level and stable supporting plane, not on the places that can easily shock or wake. Enough room should be left around the monitor so as to guarantee normal ventilation.**

- ⇒ Keep all the packaging materials for future use in transportation or storage.

- ⇒ Check the monitor and accessories

Check the monitor and its accessories one by one in accordance with the particular paper. Check to see if the parts have any mechanical damages. In case of problems, please contact us or our agent.

3.2 Connect Power

3.2.1 AC Power



- ⇒ Confirm the rated AC current is: AC 100V~240V 50/60Hz

- ⇒ Use the electrical wires provided along with the instrument, put its output end plug (round headed) into the AC current socket on the back of the monitor, and the plug of input end into a grounded socket of the mains (It must be a special socket of the hospital), connect the monitor through the earth one of electrical wires.

- ⇒ When the AC indicating light beside the power switch on the panel of the monitor is green, it means the AC power is on. And when the monitor is not connected to AC power and the built-in DC battery is used as the power source, the indicating light is orange.

 **Warning:** The monitor must be connected to a properly installed power outlet with protective earth contacts only. If the installation does not provide for a protective earth conductor, disconnect the monitor from the power line and operate it on battery power.

 **Note:** The equipment has no mains switch. The equipment is switched completely only by disconnecting the power supply from the wall socket. The wall socket has to be easily accessible.

 **Note:** For measurements in or near the heart we recommend connecting the monitor to the potential equalization system. Use the green and yellow potential equalization cable and connect it to the pin labeled with the  symbol.

3.2.2 Battery Power

The Monitor has a battery pack to provide power to the monitor whenever AC power is interrupted. The battery is generally referred to as the “battery”.

You must charge the battery before using it. There is no external charger. The battery is charged when the monitor is connected to AC power. A fully depleted battery will take about 6/12 hours to fully charge. To assure a fully charged battery that is ready for use, we recommend that the monitor be plugged into AC power whenever it is not in use.

Depending on usage, you can get about 120 minutes of battery power with a new, fully-charged battery on the monitor. NIBP and SpO₂ monitoring and the usage of the recorder will drain battery power faster than other parameters.

 **Note:** When the monitor is connected to AC current, the battery is in a state of being recharged. When it is unable to be connected to the AC current, the battery can be used to supply power, and at this time it is unnecessary to use the electrical wires, and the instrument can be switched on directly.

 **Note:** A “BATTERY LOW” message at the technical alarm information display area of the screen and an audible system alarm indicate approximate 5 minutes of battery life remaining. You should connect the monitor to an AC power source when the message is displayed.

 **Note: This monitor contains a rechargeable battery. The average life span of this type of battery is approximately three years. When replacement becomes necessary, contact a qualified service representative to perform the replacement.**

Disposal Notice

Should this product become damaged beyond repair, or for some reason its useful life is considered to be at an end, please observe all local, state, and federal regulations that relate to the disposal of products that contain lead, batteries, plastics, etc.

■ Install Battery

The battery storage is located at the bottom of the monitor, following the steps to install a battery.

- 1、 Open the battery gate according to the direction marked on the monitor.
- 2、 Turn the baffle up clockwise.
- 3、 Push the battery into the gate with the electrode point to the bottom of the monitor.
- 4、 After pushing the battery inside the storage withdraw, turn the baffle back to the middle position.
- 5、 Close the gate.

■ Uninstall battery

- 1、 Open the battery gate according to the direction marked on the monitor.
- 2、 Turn the baffle up clockwise.
- 3、 Take out the battery. Then close the gate.

3.3 Connect to the Central Monitor System

 **Warning:** Accessory equipment connected to the analog and digital interface must be certified according to the respective IEC standards (e.g. IEC 60950 for data processing equipment and IEC 601-1:1988 for medical equipment). Furthermore all configurations shall comply with the valid version of the system standard IEC 60601-1-1. Everybody who connects additional equipment to the signal input part or signal output part configures a medical system, and is therefore responsible that the system complies with the requirements of the valid version of the system standard IEC 60601-1-1. If in doubt, consult the technical service department or your local representative.

If the user intends to connect the monitor to the central monitoring system, plug its connecting electrical cable into the Network Connector interface at the back of the monitor.

 **Note:** This monitor can only be connected to the central monitoring system provided by manufacturer, do not attempt to connect this monitor to other central monitoring system.

3.4 Power on the Monitor

- ⇒ Press the power switch on the front panel of the monitor
- ⇒ About 10 seconds after the monitor is switched on, after passing the self-examination of the system, the monitor enters the monitoring screen.

 **Warning:** In case the monitor is found to be working abnormally or indication of errors appears, please do not use this monitor for monitoring and should contact the after-sale service center as soon as possible.

3.5 Connect Patient Sensors

Connect sensor cables to the relevant sockets on the monitor and put sensors on the monitored locations on the body of the patient. Refer to the relevant content of **Chapter 5** for details.



Warning: For safety reasons, all connectors for patient cables and sensor leads (with the exception of temperature) are designed to prevent inadvertent disconnection, should someone pull on the leads. Do not route cables in a way that they may present a stumbling hazard. Do not install the monitor in a location where it may drop on the patient. All consoles and brackets used must have a raised edge at the front.

Chapter 4 Operation Instructions





Note: For Concision, the following terms are used to describe one or more operations

Choose—Turn on the Trim Knob and move the cursor onto the item that needs to be changed.

Conform-- press the Trim Knob.

Select-- move the cursor onto the item and press the Trim Knob.

4.1 Main Menu

Press the  key on front panel to open **【MAIN Setup】** dialogue window, press the  key again can close the dialogue window.

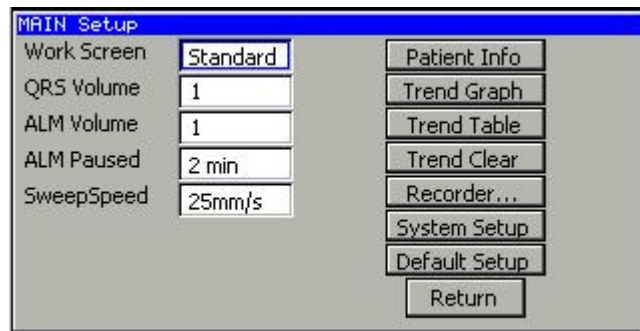

4.2 Work screen

Select **【MENU】** --> **【Work Screen】** , can choose which work screen is used in patient monitoring.

☰ Standard

Standard display screen. Display one ECG wave, PLETH wave, RESP wave and all measurement parameters.



☰ **Big Char**

Big char display screen. Display one ECG wave, PLETH wave and vital measurement parameters are displayed in magnified characters.

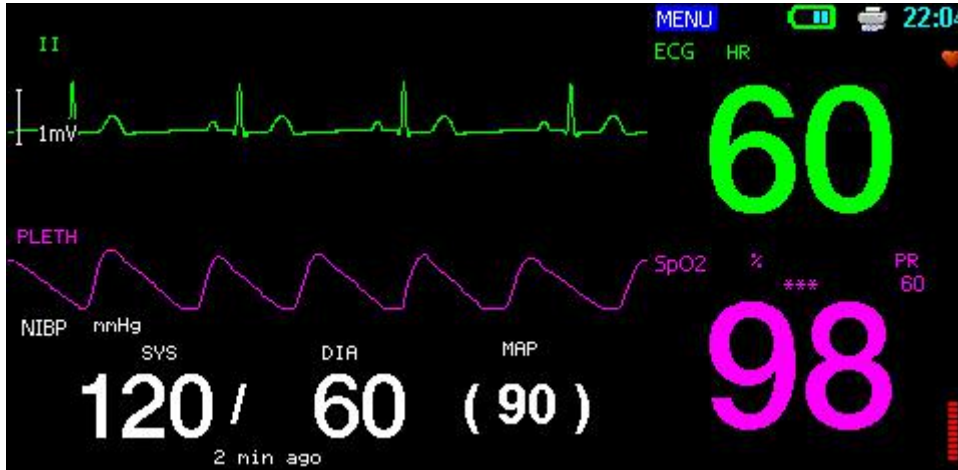

☰ **Short Trend**

Short trend display screen. Dynamic short trends of HR/PR, SpO₂ and RR and one ECG wave, PLETH wave, RESP wave and all measurement parameters display on the screen synchronously.

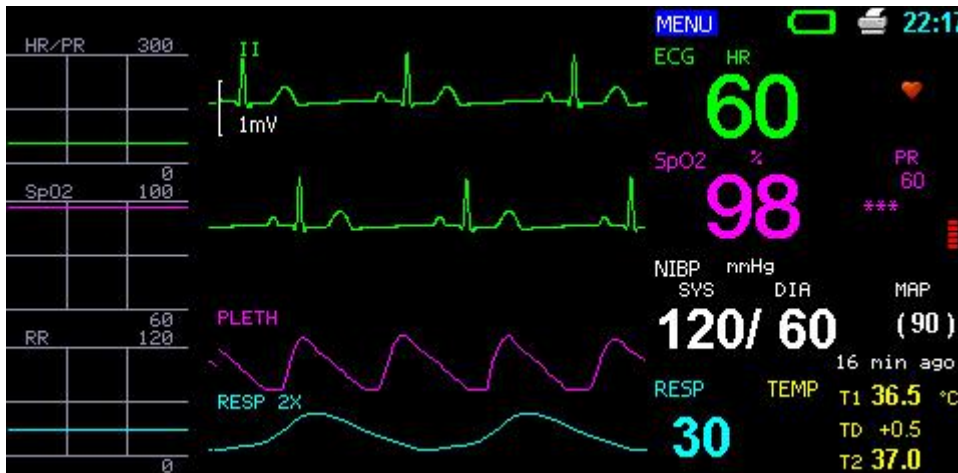

4.3 Setup volume

☰ **QRS volume**

Select **【MENU】** --> **【QRS volume】**, options are 0~3. Select 0 to close the QRS volume, Select 3 to setup maximal QRS volume.

 **Note:** While SpO₂ is monitoring, the system will adjust the pitch tone of QRS

volume according to SpO₂ value measured automatically.

☰ **Alarm volume**

Select **【MENU】** --> **【ALM volume】**, options are 0~3. Select 0 to close the alarm volume, Select 3 to setup maximal alarm volume.

4.4 Setup wave sweep speed

Select **【MENU】** --> **【Sweep Speed】**, options are 12.5mm/s, 25mm/s and 50mm/s. This option influences ECG, PLETH waveform displays and recording speed of the recorder.

4.5 Setup patient information

Select **【MENU】** --> **【Patient Info】** button, and a following patient information dialogue window will be displayed.

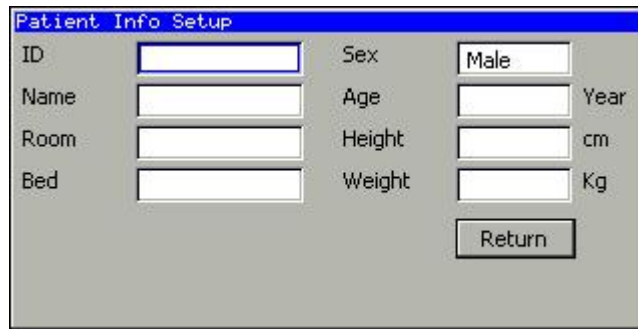

Patient information includes:

ID	The ID number of patient (setup due to the actual condition of the hospital).
Name	The name of patient. The length of name can be 10 characters at most.
Room	The number of patient sickroom.
Bed	The bed number of patient.
Height	The height of patient.
Sex	The sex of patient (male, female).
Age	The age of patient.
Weight	The weight of patient.

4.6 System setup

Select **【MENU】** --> **【System Setup】** button, and a following system setup dialogue window will be displayed.



4.6.1 System setup

1. Select **【MENU】** --> **【System Setup】** --> **【Language】**, select the displaying language of the system according to the user's favorite.
2. Exit the dialogue windows.

4.6.2 Setup demo function

≡ Enter demo mode

Select **【MENU】** --> **【System Setup】** --> **【Demo】**, select <ON>, input the DEMO password and enter OK.

≡ Exit demo mode

Select **【MENU】** --> **【System Setup】** --> **【Demo】**, select <OFF>.

👉 Note: The purpose of waveform demonstration is only to demonstrate the machine performance, and for training purpose. In clinical application, this function is not recommended because the DEMO will mislead the hospital workers to treat the waveform and parameter as actual data of the patient, which may result in delay of treatment or mistreatment.

4.6.3 Setup system time

Select **【MENU】** --> **【System Setup】**: setup <Year>, <Mon>, <Date>, <Hour>, <Min>, <Sec> and select **【OK】** to confirm.

! Caution: The change of time will influence the trend data saved, or lose data. Setup time before monitoring and restart the monitor after setup is suggest. The changed time will be available after exit the current window.

4.6.4 Setup display color

Select **【MENU】** --> **【System Setup】** --> **【Color Setup】**, and a following color setup window will be displayed.

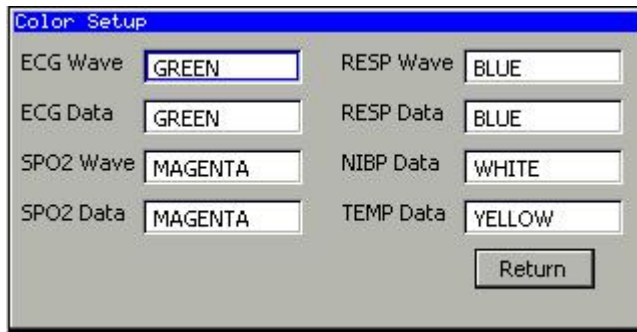

User can change the display colors of waveforms and data displayed on screen freely.

4.6.5 Setup nurse call function

Nurse Call is a function that the monitor will send signal to call nurse when the alarm conditions destined are occurred.

The monitor has a nurse call output socket, connect the socket to the nurse call system of the hospital by the nurse-call cable provided along with the monitor, the nurse call function can be realized.

The nurse call function is valid when the following conditions are concurrent:

1. The nurse call function is open.
2. An alarm condition destined is occurred.
3. The monitor is not in the state of alarm paused or system silence.

Select **【MENU】** --> **【System Setup】** --> **【Nurse Call】** , and a following nurse call setup window will be displayed.



ALM Condition	Select the alarm condition type that can trigger the nurse call action. The options of alarm condition type include physical alarm condition and technical alarm condition.
ALM Level	Select the alarm level that can trigger the nurse call action. The options of alarm level include low, medium and high alarm levels.

If there are nothing selected in the 【ALM Condition】 and the 【ALM Level】 , any alarm occurrence will not trigger the nurse call action.

Warning: The nurse call function should not be used as the primary patient alarm inform source. It is necessary for combining the auditory and visual alarm signal and the patient clinical feature and symptom as the primary information to medical and nursing staff about the physiological condition of the patient.

4.6.6 System information

Select 【MENU】 --> 【System Setup】 --> 【About】, the system information window will be displayed, system information includes software version and manufacturer information.

4.7 Setup recorder

Select 【MENU】 --> 【Recorder...】 , a following setup recorder window will be displayed.



Auto REC	Turn off auto recording or select the interval to do auto recording. The content of auto recording includes one ECG waveform, PLETH waveform, respiration waveform and all parameters measured.
REC Length	Select the recording length of waveform in auto recording. The Options are 8s, 12s and 16s.
ALM REC Interval	Select the interval of alarm recording when the alarm is occurring continuous. Alarm recording function will be disabled when <OFF> is selected.
Grid	Select if the grid is recorded in the waveform recording area of the recording paper. Options are <OFF>, <ON>.

4.8 Restore default system setup

Select **【MENU】** --> **【Default Setup】**, and a following default system setup window will be displayed, select one item in this window will restore the system setup to default setup. There are three options: ADULT, CHILD, NEONATAL.

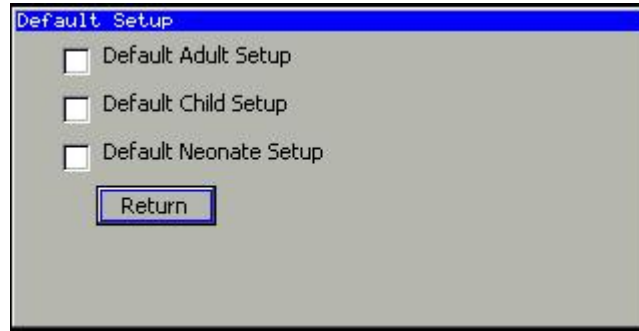

4.9 Display of trend

4.9.1 Display of trend map

Select **【MENU】** --> **【Trend Graph】** ,, and a following trend graph window will be displayed.



Parameter	One of the parameters of HR, SpO ₂ , RR and NIBP can be chosen to see over its trend graph.
Interval	User can choose from 4, 8, 12, 16, 24, 48 and 72 hours, which is the displayed length of trend graph time in one page.
Prev	Turn to previous page.
Next	Turn to next page.
Return	Exit trend graph window.

4.9.2 Display of trend data

Select **【MENU】** --> **【Trend Table】** , and a following trend data window will be displayed.

Time	HR	SYS/DIA	SPO2	RR	T1	T2
Apr-18 08:36	60		98	30	36.5	37.0
Apr-18 08:35	60		98	30	36.5	37.0
Apr-18 08:34	60		98	30	36.5	37.0
Apr-18 08:33	60		98	30	36.5	37.0
Apr-18 08:32	60	120/ 60	98	30	36.5	37.0
Apr-18 08:31	60		98	30	36.5	37.0
Apr-18 08:30	60		98	30	36.5	37.0

Page: 1 / 1
Interval: 1 min [Prev] [Next] [Record] [Return]

Interval	User can choose from 1, 2, 3, 4, 5, 10, 15, 30, 60, 90 minutes and 2, 4, 8 hours, which is the displayed interval between trend data item.
Prev	Turn to previous page.
Next	Turn to next page.
Record	Print the trend data in current screen through recorder.
Return	Exit trend table window.

4.9.3 Clear trend data

Select **【MENU】** --> **【Trend Clear】** , and a following trend clear prompt window will be displayed.



Select **【YES】** will delete all data in trend graph, trend table and NIBP review table.

👉 Note: The Monitor can store maximum 72 hours trend data and 600 items of NIBP measurement result. When the maximum trend data storage time is achieved, the monitor would not save new trend data unless the old trend data cleared.

4.10 Display information on the screen

4.10.1 System state display area

The system state is displayed at the right top of the screen.

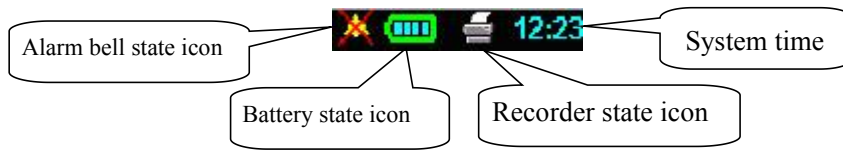

The auditory alarm signal turns off, that is to say, when an alarm takes place, the monitor will not make any sound.



The recorder is ready. The icon will flicker when the recorder is working.



Recorder is lack of paper, the door is not closed or other faults.



The battery is full.



The battery is half-full.



The battery is empty.



Note: When the battery is empty, the system will alarm, in order to remind the users to engage the AC power and charge up. If the monitor has not been charged up in time, the monitor will shut down in 5 to 15 minutes because of short of power.

4.10.2 Alarm information display area

Alarm information is displayed at the top of the screen.

Alarm information region:

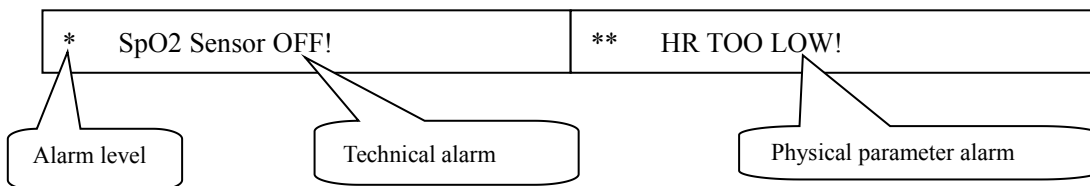

Alarm level:

- * Low-level alarm
- ** Middle-level alarm
- *** High-level alarm

Parameter alarm, the parameter will display flickeringly in order to warn.

Chapter 5 Parameters Measurement

5.1 Measurement of ECG/HR

5.1.1 Principles of Measuring

Before the mechanical contraction, the heart will firstly produce electrization and biological current, which will be conducted to body surface through tissue and humors; the current will present difference in potential in different locations of the body, forming potential difference ECG, also known as body surface ECG or regular ECG, is obtained by recording this changing potential difference to form a dynamic curve. The Monitor measures the changes in the body surface potentials caused by the heart of the patient, observes the cardioelectric activities, records the cardioelectric waveforms and calculates the HR through the multiple electrodes connected to various cables. The measurement range of HR is 10~300 bpm.

5.1.2 Precautions during ECG Monitoring

 **Warning:** Before connecting the ECG cables to the monitor, please check if the lead wires and cables have been worn out or cracked. If so, they should be replaced.

 **Warning:** It is imperative to only use the ECG cables provided with the instrument by manufacturer.

 **Warning:** The EQUIPMENT is capable of displaying the ECG signal in the presence of pacemaker pulses without rejecting pacemaker pulses.

 **Warning:** To avoid burning, when the electrotome operation is performed, the electrodes should be placed near the middle between ESU grounding pad and electrotome and the electrotome should be applied as far as possible from all other electrodes, a distance of at least 15 cm/6 in. is recommended.

 **Warning:** When the electrotome operation is performed, electrodes should be placed on the circle which centre is the operation area, the ECG leadwires should be intertwined as much as possible. The main unit of the instrument should be placed at a distance from the operation table. Electrical wires and the ECG lead cables should be partitioned and should not be in parallel.

 **Note:** When several parts of equipment are interconnected, the total leakage current is limited to the safety range according to standards IEC 60601-2-27.

 **Warning:** The monitor is protected against defibrillation effect. When applying defibrillator to the patient, the monitor will experience transient disorderly waveforms. If the electrodes are used and placed correctly, the display of the monitor will be restored within 10 seconds. During defibrillation, the chest leads such as $V_1 \sim V_6$ should be removed and such limb electrodes as RA, LA, RL, LL should be moved to the side of the limbs.

 **Warning:** All the electrodes and conducting part shall not be into contact with any other conductors including the ground. For the sake of patient safety, all the leads on the ECG cables must be attached to the patient.

 **Warning:** When conducting defibrillation, it is imperative to only use the electrodes recommended by manufacturer.

 **Warning:** Do not come into contact with the patient, bed and the monitor during defibrillation.

 **Warning:** The Monitor cannot be directly applied to heart and cannot be used for the measurement of endocardio ECG.

5.1.3 Preparing the Measurement of ECG/HR

- 1) Plug the ECG cable into the ECG socket of the monitor.
- 2) Place the electrodes onto the body of the patient and connect them to the relevant lead wires of the ECG cables, and at this moment ECG waveforms will appear on the screen.
- 3) Set the parameters relevant to ECG monitoring.

5.1.4 Connecting the ECG Cables to the Monitor

The Monitor is provided with three different ECG cables relevant to 3-Lead or 7-Lead ECG monitoring:

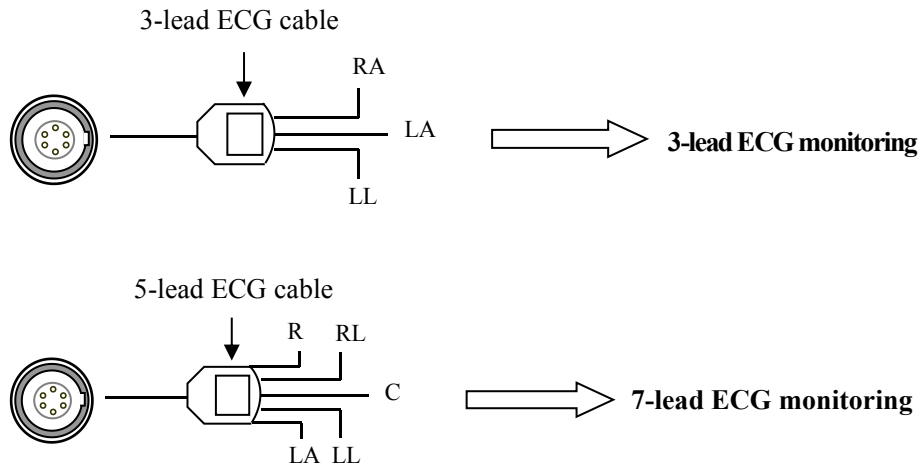

1) 3-lead ECG cable

- ⇒ Including three limb leads: RA, LL, and LA.
- ⇒ Realize 3-lead ECG monitoring.

2) 5-lead ECG cable

- ⇒ Including four limb leads: RA, RL, LL, LA and one chest-lead C.
- ⇒ Realize 7-lead ECG monitoring.

5.1.5 Connecting the ECG Electrodes to the Patient

1) Connection steps

- ⇒ Clean the patient's skin and remove the oil stains, sweat stains on the skin with alcohol. If necessary, remove the body hair at the locations where the electrodes are to be placed or grind off the stratum corneum and clean it with alcohol.
- ⇒ Check if the buttons on the electrodes are clean and free of damage.
- ⇒ Place the electrodes on the body of patient. Before attaching, smears some conducting cream on the electrodes if the electrodes are not electrolyte self-supplied.
- ⇒ Connect the cable leads to the electrodes through the buttons of the electrodes.

 **Note:** For patients who tremble a lot or patients with especially weak ECG signals, it might be difficult to extract the ECG signals, and it is even more difficult to conduct HR calculation. For severely burnt patients, it may be impossible to stick the electrodes on and it may be necessary to use the special pin-shape electrodes. In case of bad signals, care should be taken to place the electrodes on the soft portions of the muscle.

 **Note:** Check the irritation caused by each electrode to the skin, and in case of any inflammations or allergies, the electrodes should be replaced and the user should relocate the electrodes every 24 hours or at a shorter interval.

 **Note:** When the amplifier is saturated or overloaded, the input signal is medical meaningless, then the equipment gives an indication on the screen.

2) Location for electrode placement

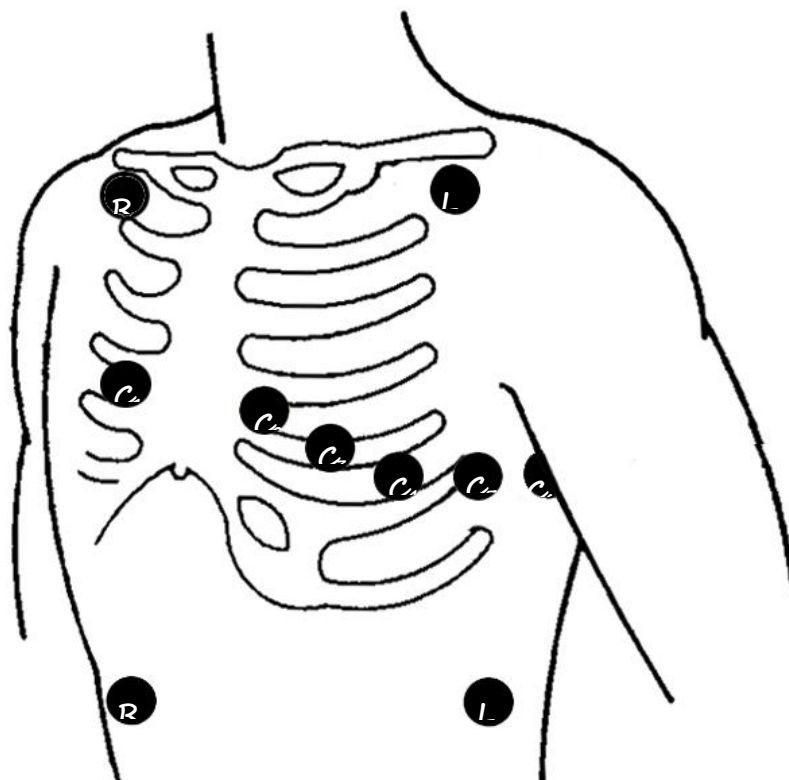

The following table shows the lead name to identify each lead wire and its associated color of AHA and IEC standards.

AHA Label	AHA Color	IEC Label	IEC Color	Location
RA	White	R	Red	Under the clavicle of the right shoulder.
LA	Black	L	Yellow	Under the clavicle of the left shoulder.
RL	Green	N	Black	Right lower abdomen.
LL	Red	F	Green	Left lower abdomen.
V ₁	Brown	C1	White	4th intercostal space on the right sternum side.
V ₂	Yellow	C2	Yellow	4th intercostal space on the left sternum side.
V ₃	Green	C3	Green	Center of the line connecting V ₂ and V ₄ .
V ₄	Blue	C4	Brown	Node of the left 5th intercostal space and the mid-clavicular line.
V ₅	Orange	C5	Black	Node with the left anterior axillary line at the same height with V ₄ .
V ₆	Purple	C6	Purple	Node with the left mid-axillary line at the same height with V ₄ .

When conducting 3-leads ECG monitoring, use 3-lead ECG cable. The three limb-leads of RA, LA and LL should be placed on the relevant locations. This connection can establish the lead of I, II, III.

When conducting 7-leads ECG monitoring, use 5-lead ECG cable. The four limb-leads of RA, LA, RL and LL should be placed on the relevant locations. This connection can establish the lead of I, II, III, aVR, aVL, aVF; according to actual needs, chest lead C can be placed on any of the locations between C₁~C₆, respectively making one lead of V₁~V₆ established.

5.1.6 ECG Setup menu

Select the <ECG> button on the screen, and a following ECG setup window will be displayed.

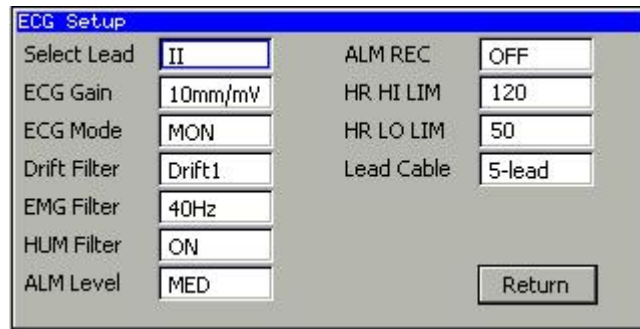

Select Lead	Select the monitoring lead, the selections: <I>, <II>, <III>, <aVR>, <aVL>, <aVF> and <V->.
ECG Gain	Select the gain of the ECG waveform, the selections: <2.5mm/mV>, <5mm/mV>, <10mm/mV>, <20mm/mV>, <40mm/mV> and <AUTO>.
ECG Mode	There are four operation modes, which are unfiltered, operation, monitoring and user. They are identified as: < UNFI > , <OPS> , <MON>, <USER> in the ECG menu.
Drift Filter	Drift filter. Three options are provided: <OFF> (time-constant > 3.2 seconds, the comeback time of ECG waveform is long, and the distortion of the waveform is little), <Drift 1> (time-constant > 0.3 second, the comeback time of ECG waveform is shorter), <Drift 2> (time-constant > 0.15 second, the comeback time of ECG waveform is shortest, and the distortion of the waveform is obvious).
EMG Filter	The low pass filter in order to filtrate the EMG noise, the selections: <OFF>, <25Hz > and <40Hz >.
HUM Filter	The notch filter in order to filtrate the HUM noise. Select <ON> open the filter, select <OFF> close the filter.
ALM Level	Set the alarm level of ECG parameter, the selections: <OFF>, <LOW >, <MED > and <HIGH >.
ALM REC	Select <ON>, the alarm of ECG/HR parameter will trigger alarm recording. Select <OFF>, the alarm of ECG/HR parameter will not trigger alarm recording.
HR HI LIM	Select the upper limit of HR alarm, adjustable range: 0 ~ 350, adjust continuously, equal or above the lower limit.
HR LO LIM	Select the lower limit of HR alarm, adjustable range: 0 ~ 350, adjust continuously, equal or below the upper limit.
LEAD Cable	Select the ECG input cable, the selections: <3- lead>, <5-lead>.

The states of the filter under various modes of ECG:

ECG mode \ Filter	Drift filter	HUM filter	EMG filter
UNFI	OFF	OFF	OFF
OPS	Drift 2	ON	25Hz
MON	Drift 1	ON	40Hz
USER	Optional	Optional	Optional

Note: Under the mode of UNFI, OPS and MON, the state of the filter cannot be regulated. Only under the state of USER can the state be regulated.

Caution:

- When “3 Lead” is selected as <Lead Cable>, ECG is in 3-lead input mode, and only Lead I, II or III can be measured.
- When “5 Lead” is selected as <Lead Cable>, ECG is in 5-lead input mode, and Lead I, II, III, aVR, aVL and aVF and one chest lead can be measured.

5.1.7 Display of ECG parameter

☰ Waveform display



☰ Data display



Caution: Whenever ECG leads are connected, heart rate measured by ECG will display on the position of heart rate parameter. When ECG leads are not connected, while SpO₂ sensor is connected, pulse rate will display on the position of heart rate parameter automatically.

5.1.8 Maintenance and Cleaning

If there is any sign that the ECG cable may be damaged or deteriorated, replace it with a new one instead of continuing its application on the patient.

Cleaning: Use fine-hair cloth moistened in mild soap or cleaning agent containing 70% ethanol to clean the equipment.

Sterilization: To avoid extended damage to the equipment, sterilization is only recommended when stipulated as necessary in the hospital maintenance schedule, sterilization facilities should be cleaned first.

Recommended sterilization material:

- ⇒ Ethylate: 70% alcohol, 70% isopropanol
- ⇒ Acetaldehyde

Disinfection: To avoid extended damage to the equipment, disinfection is only recommended

When stipulated as necessary in the Hospital Maintenance Schedule. Disinfection facilities should be cleaned first.

5.2 Measurement of RESP

5.2.1 Principles of Measuring

The Monitor measures RESP with the method of impedance. When a patient exhales and inhales, changes will take place in the size and shape of the thoracic cavity, causing consequent changes in the impedance between the two electrodes installed at the patient's chest. Based on the cycle of impedance changes, the respiration rate can be calculated. The measuring range of respiration rate is 0~120 times/min.

5.2.2 Preparing the Measurement of RESP

- 1) Plug the ECG cable into the ECG socket of the monitor.
- 2) Place the various pads of the electrodes onto the body of patient and connect them to the relevant lead cables. At this moment, the screen will show RESP waves and the RESP rate will be calculated.
- 3) Set the parameters relevant to RESP monitoring.

5.2.3 Connect the ECG Cable with Patient and the Monitor

To measure RESP parameters, it is unnecessary to use other cables and it is only necessary to use the two RA and LL leads in the ECG cable.



Warning: For the sake of safety, all the leads on the ECG cable must be connected to the body of patient.

5.2.4 RESP Setup menu

Select the <RESP> button on the screen, and a following RESP setup window will be displayed.

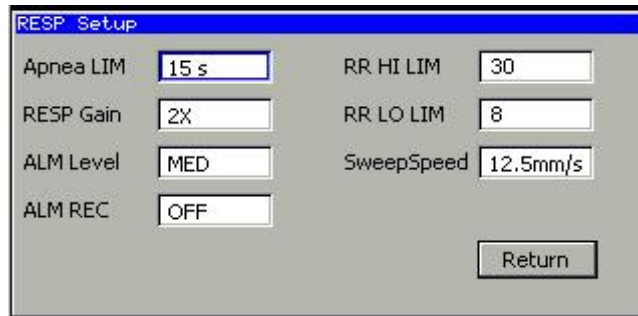

Apnea LIM	Define the concept of choke. When the duration of no RESP reach this limit, apnea alarm will be triggered. Range: 10~60s.
RESP Gain	Select the magnify times of RESP gain. Options: <1x>, <2x>, <4x>.
ALM Level	Setup alarm level of RESP parameters, the selections: <OFF>, <LOW>, <MED> and <HIGH> are optional.
ALM REC	Select <ON>, the alarm of RESP parameter will trigger alarm recording. Select <OFF>, the alarm of RESP parameter will not trigger alarm recording.
RR HI LIM	Select the alarm upper limit of RESP rate. Range: 0 ~ 120, adjust continuously, equal or above the lower limit.
RR LO LIM	Select the alarm lower limit of RESP rate. Range: 0 ~ 120, adjust continuously, equal or below the upper limit.
Sweep Speed	Set the sweep speed of RESP waveform. Options are <25mm/s>, <12.5mm/s>, <6.25mm/s>.

5.2.5 Display of RESP parameter

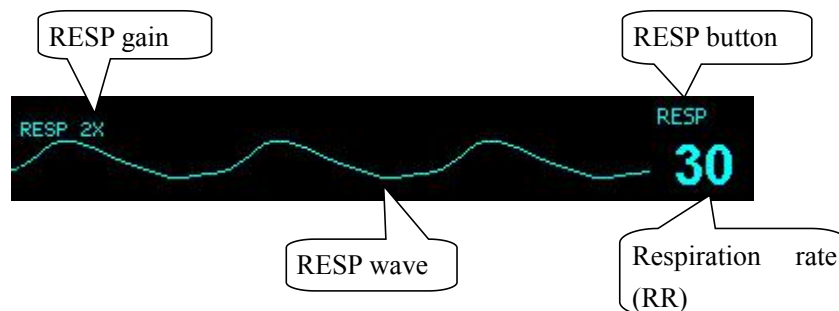

5.2.6 Maintenance and Cleaning

No special operation demanded. Please refer to 5.1.10 of chapter 5.

5.3 Measurement of SpO₂/Pulse

5.3.1 Principles of Measuring

The measurement of degree of blood oxygen saturation (also known as pulse oxygen saturation, usually shortened as SpO₂) adopts the principles of light spectra and volume tracing. The LED emits lights with two specific bandwidths, which are selectively absorbed by hemoferrum and desoxyhemoglobin. The optical receptor measures the changes in the light intensity after the light passes the capillary network and estimates the ratio of hemoferrum and the total hemoglobin. The measurement range of SpO₂ is 0~100%.

$$\text{Degree of pulse oxygen saturation \%} = \frac{\text{hemoferrum}}{\text{hemoferrum} + \text{desoxyhemoglobin}} \times 100\%$$

Abnormal hemoglobin, carboxyhemoglobin, oxidative hemoglobin are not directly measured, for they are not the affecting factors in the measurement of SpO₂

The sensor measurement wavelengths are nominally 660nm for the Red LED and 940nm for infrared LED.

The Monitor adopts FFT filter and signal correlation techniques to deal with SpO₂ module's pulse waveform signals. Before the measurement of SpO₂, the noise produced in the false trace is smoothed so as to the eliminate disturbance in the measurement of saturation. In case of weak blood pulse, the noise produced by some confinements of electrical properties is greatly reduced.

The Monitor is designed for measurement and recording of functional saturation.

5.3.2 Preparing the Measurement of SpO₂/Pulse

- 1) Plug the SpO₂ sensor cable into the SpO₂ socket of the monitor.
- 2) Put the SpO₂ sensor onto the finger of the patient, and the screen should display SpO₂ waveforms, and the SpO₂ value and pulse rate should be displayed.
- 3) Set up the parameters relevant to SpO₂ and pulse monitoring.

5.3.3 Connecting to Patient and Monitor

Plug the SpO₂ sensor cable into the socket marked with SpO₂, then put the sensor onto the finger of the patient, as shown in following Fig.

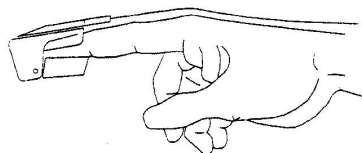

Fig. Connection of SpO₂ sensor with the patient

After the SpO₂ sensor is connected to the patient, the screen shall display SpO₂ waveforms and then it shall calculate the SpO₂ value and pulse rate value.

! **Caution:** In case it is necessary to add a clip to fix the fingertip sensor, the cable instead of the sensor itself should be clipped. Please note that the cable of sensor should not be pulled with force.

👉 **Note:** Frequent movements of the sensor may result in errors in the readings of the monitor.

💣 **Warning:** In case NIBP and SpO₂ are measured at the same time, please do not place the SpO₂ sensor and the NIBP cuff on the same end of the limb, for the measurement of NIBP will block blood flow, affecting the measurement of SpO₂.

💣 **Warning:** Do not conduct SpO₂ measurement on the finger smeared with fingernail oil, otherwise unreliable measurement results might be produced.

👉 **Note:** When using SpO₂ sensor, care should be taken to shield external light sources, such as light of thermo therapy or ultraviolet heating light, otherwise the measurements may be disturbed. Under such conditions as shock, hypothermia, anemia or the use of blood vessel-activating drugs, and with the existence of such substances as carboxyhemoglobin, methemoglobin, methylene blue the result of the SpO₂ measurement will be possibly not accurate.

👉 **Note:**

- Make sure the nail faces to the light window.
 - The wire should be on the backside of the hand.
 - SpO₂ waveform is not proportional to the pulse volume.
-

 **Warning: Do not use the sterile supplied SpO₂ sensors if the packing or the sensor is damaged and return them to the vendor.**

 **Warning: Prolonged and continuous monitoring may increase jeopardy of unexpected change of dermal condition such as abnormal sensitivity, rubescence, vesicle, repressive putrescence, and so on. It is especially important to check the sensor placement of neonate and patient of poor perfusion or immature dermogram by light collimation and proper attaching strictly according to changes of the skin. Check per 2~3 hours the sensor placement and move it when the skin deteriorates. More frequent examinations may be required for different patients.**

5.3.4 SpO₂ Setup menu

Select the <SpO₂> button on the screen, and a following SPO₂ setup window will be displayed.

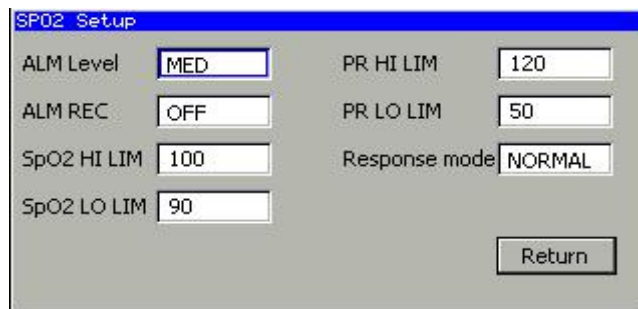

ALM Level	Setup alarm level of SpO ₂ parameters, the selections: <OFF>, <LOW>, <MED> and <HIGH> are optional.
ALM REC	Select <ON>, the alarm of SpO ₂ parameter will trigger alarm recording. Select <OFF>, the alarm of SpO ₂ parameter will not trigger alarm recording.
SpO₂ HI LIM	Select the SpO ₂ alarm high limit, range: 0~100 , adjust continuously, equal or above the lower limit.
SpO₂ LO LIM	Select the SpO ₂ alarm low limit, range: 0~100 , adjust continuously, equal or below the upper limit.
PR HI LIM	Select the PR alarm high limit, range: 0~255 , adjust continuously, equal or above the lower limit.
PR LO LIM	Select the PR alarm low limit, set range: 0~255 , adjust continuously, equal or below the upper limit.
Response mode	Select how fast of SpO ₂ value calculation, the selections: <FAST>, <NORMAL> and <SLOW> are optional.

5.3.5 Display of SpO₂ parameter

- ☰ Waveform display

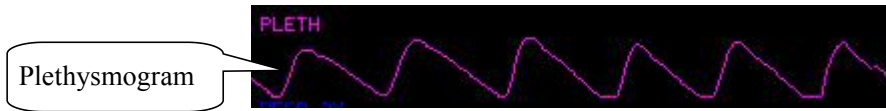

- ☰ Data display

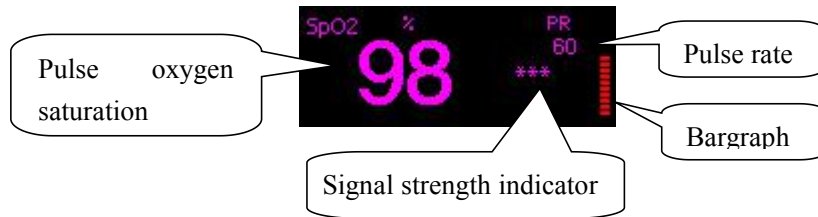

Signal strength indicator: Uses to indicate if the SpO₂ signal strength measured is adequacy.

Indicator	Description
“Weak Signal”	The signal strength is too weak to measuring.
“*”	The signal strength is low.
“**”	The signal strength is good.
“***”	The signal strength is best.

Warning: When the “Weak Signal” is indicated, it means the quality of the signal obtained by the SpO₂ probe is too bad. User should check the patient’s condition and move the probe to other appropriate position.

Note: When ECG leads are not connected, while SpO₂ sensor is connected, pulse rate will display on the position of heart rate parameter automatically.

5.3.6 Maintenance and Cleaning

Warning:

- Do not subject the sensor to autoclaving.
- Do not immerse the sensor into any liquid.
- Do not use any sensor or cable that may be damaged or deteriorated.

For cleaning:

Use a cotton ball or a soft mull moistened with hospital-grade ethanol to wipe the surfaces of the sensor, and then dry it with a cloth. This cleaning method can also be applied to the luminotron and receiving unit.

The cable can be cleaned with 3% hydrogen dioxide, 7% isopropanol, or other active reagent. However, connector of the sensor shall not be subjected to such solution.

 **Note: When disposing the disposable SpO₂ probe or useless SpO₂ probe, please observe all local, state, and federal regulations that relate to the disposal of this products or similar products.**

5.4 Measurement of TEMP

5.4.1 Brief Introduction to Measurement of TEMP

The Monitor measures temperatures with TEMP sensors, and the measurement range is 0.0°C~50.0°C (32.0°F~122.0°F).

The TEMP module of the monitor uses TEMP cable compatible with YSI-400. The minimum time to get accurate temperature measuring value is 3 minutes.

The Monitor has two TEMP measurement sockets, and can measure the temperature of two channels at the same time.

5.4.2 Preparing the Measurement of TEMP

- 1) Plug the TEMP cables into the TEMP sockets of the monitor.
- 2) Place the TEMP sensors on body of patient and the screen will show the value of TEMP measurement.
- 3) Set the parameters relevant to TEMP.

5.4.3 Connecting Patient and Monitor

Plug the TEMP cable into the sockets marked with TEMP (either of TEMP1 and TEMP2), and then stick the TEMP sensor securely onto the body of patient.

 **Caution: The TEMP sensor and cables should be handled with care. When not in use, the sensor and the cable should be rounded into loose ring shape.**

 **Warning: The calibration of temperature measurement is necessary for every two years (or as frequently as dictated by your Hospital Procedures Policy). When you need calibrate the temperature, contact the manufacture please.**

 **Note:** The self-test of the temperature measurement is performed automatically once every 10 minutes during the monitoring. The test procedure lasts about one second and does not affect the normal measurement of the temperature monitoring.

 **Note:** If Temperature to be measured beyond probe's measuring range, over measuring range alarm will display on the screen. Check out if probe is on the corresponding patient body site, or change it to other site on the patient.

 **Note:** if “TEMP self-check error” displays on the screen, it is possibly that something is wrong with the temperature capture circuit, the operator should stop using the monitor and contact with the company.

5.4.4 TEMP Setup menu

Select the <TEMP> button on the screen, and a following TEMP setup window will be displayed.

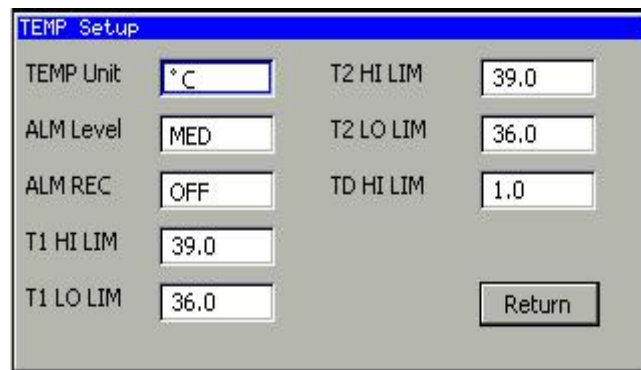

TEMP Unit	Select the unit of the TEMP value displayed, the selections: <°C>, <°F>.
ALM Level	Set TEMP parameters' alarm level, the selections: <OFF>, <LOW>, <MED> and <HIGH>.
ALM REC	Select <ON>, the alarm of TEMP parameter will trigger alarm recording. Select <OFF>, the alarm of TEMP parameter will not trigger alarm recording.
T1 HI LIM	Select the channel 1 TEMP alarm high limit, set range: 0~50 °C , adjust continuously, equal or above the lower limit.
T1 LO LIM	Select the channel 1 TEMP alarm low limit, set range: 0~50 °C , adjust continuously, equal or below the upper limit.
T2 HI LIM	Select the channel 2 TEMP alarm high limit, set range: 0~50 °C , adjust continuously, equal or above the lower limit.

T2 LO LIM	Select the channel 2 TEMP alarm low limit, set range: 0~50 °C , adjust continuously, equal or below the upper limit.
TD HI LIM	Select the difference alarm high limit between channel 1 and channel 2 TEMP, set range: 0~5 °C .

5.4.5 Display of TEMP parameter

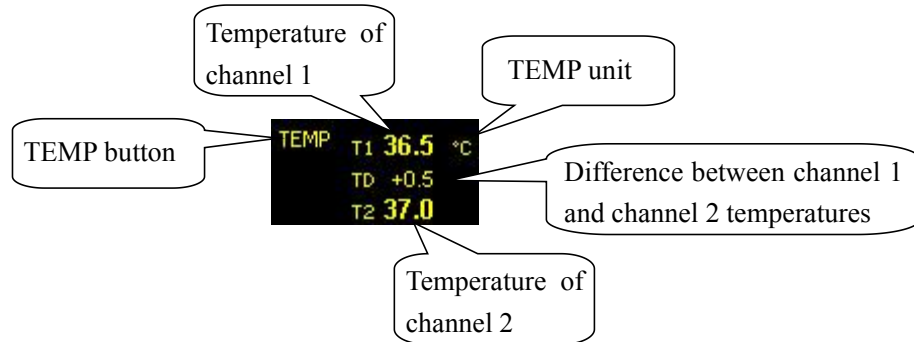



5.4.6 Maintenance and Cleaning

Reusable temp probes

1. The temp probe should not be heated above 100 °C . It should only be subjected briefly to temperatures between 80 °C and 100 °C .
2. The probe must not be sterilized in steam.
3. Only detergents containing no alcohol can be used for disaffection.
4. The rectal probes should be used, if possible, in conjunction with a protective rubber cover.
5. To clean the probe, hold the tip with one hand and with the other hand rubbing the probe down in the direction of the connector using a moist lint-free cloth.

 **Warning: Disposable TEMP probes must not be re-sterilized or reused.**

 **Note: For protecting environment, the disposable TEMP probe must be recycled or disposed of properly.**

 **Disposal Notice: Should the TEMP probe become damaged beyond repair, or for some reason its useful life is considered to be at an end, please observe all local, state, and federal regulations that relate to the disposal of this products or similar products.**

5.5 Measurement of NIBP

5.5.1 Brief Introduction to Measurement of NIBP

The Monitor automatically conducts measurement of NIBP with the method of shockwave. The method of shockwave indirectly estimates the systolic and diastolic pressures within the blood vessels by measuring the change of the pressure within blood pressure cuff along with the volume of the arteries and calculates the average pressure.

The measurement time of BP on a calm patient is less than 40 seconds, and when each measurement ends, the cuff automatically deflates to zero.

The monitor applies to any standards of the cuffs for neonate, child and adult (including the cuffs used for arms and legs).

The monitor measures the blood pressure during the time of deflation. The monitor automatically conducts the second and third inflation measurements in case during the first inflation it is unable to measure the value of BP, and gives out the information for measurement failures.

The longest cuff pressure maintaining duration is 120 seconds (90 seconds in neonate mode), and when the time is exceeded, the air will be deflated automatically. The monitor has been designed with hardware protection circuit regarding overpressure, errors of microprocessors, and the occurrence of power failure.

5.5.2 Preparing Measurement of NIBP

- 1) Plug the air hose of the cuff into the NIBP socket of the monitor and tighten it clockwise to ensure secure contact of the plug and the socket (Please note that the plug should be loosened by turning counterclockwise first before unplugging).
- 2) Tie the cuff on the arm of patient.
- 3) Set the parameters and modes relevant to NIBP.



Note: Make sure that the air conduit connecting the blood pressure cuff and the monitor is neither blocked nor tangled, and avoid compression or restriction of air conduit.

5.5.3 Connecting to Patient and the Monitor

Plug the connector of air hose on cuff into the socket marked with NIBP and install the cuff onto the arm of patient. Make sure the mark of Φ on the cuff is placed on the femoral artery of the arm and the air hose should be below the cuff so as to ensure the air hose is not snarled after coming out of the cuff. The white line on the cuff should be within the range of “”, otherwise it will be necessary to replace it with a more suitable cuff (smaller or bigger one). The cuff should be placed on the same plane with the heart so as to prevent the errors in readings caused by the effects of hydrostatics of

the blood column between the heart and the cuff. If the position of the cuff is higher than the plane of heart, the measured BP readings tend to be smaller; in case the position of the cuff is lower than the plane of the heart, the measured BP readings tend to be higher.

Note: The accuracy of measurement of BP depends on the suitability of the cuff. Select the size of the cuff according to the size of the arm of patient. The width of the cuff should be 40% of the circumference of the upper arm or 2/3 of the length of the upper arm.

Warning:

- You must not perform NIBP measurements on patients with sickle-cell disease or under any condition that the skin is damaged or expecting to be damaged.
- For a thrombasthemia patient, it is important to determine whether measurement of the blood pressure shall be done automatically. The determination should be based on the clinical evaluation.
- Prolonged non-invasive blood pressure measurements in Auto mode may be associated with purport, ischemia and neuropathy in the limb wearing the cuff. When monitoring a patient, examine the extremities of the limb frequently for normal color, warmth and sensitivity. If any abnormality is observed, stop the blood pressure measurements.

5.5.4 NIBP Setup menu

Select the <NIBP> button on the screen, and a following NIBP setup window will be displayed.

NIBP Setup			
Auto Time	MANU	DIA HI LIM	90
Patient Type	Adult	DIA LO LIM	50
NIBP Unit	mmHg	MAP HI LIM	110
ALM Level	MED	MAP LO LIM	60
ALM REC	OFF	REVIEW	STAT
High Press	OFF	Reset	Air Leakage
SYS HI LIM	160		
SYS LO LIM	90		Return

Auto Time	Interval time for automatic measuring, the selections: MANU, 1, 2, 3, 4, 5, 10, 15, 20, 30, 45, 60, 90 minutes, 2, 4, 8, 12 hours. Pick MANU selection to set up the measuring mode to manual.
Age	Select the patient type of measurement, the selections: <Adult>, <Child>, <Neo> (neonate).
NIBP Unit	Selects the unit of NIBP measurement, option: <kPa>, <mmHg>.
ALM Level	Set NIBP parameters' alarm level, the selections: <OFF>, <LOW>, <MED> and <HIGH>.
ALM REC	Select <ON>, the alarm of NIBP parameters will trigger alarm recording. Select <OFF>, the alarm of NIBP parameters will not trigger alarm recording.
High Press	This item is optional when the <Age> is adult. It is usually used when the systolic blood pressure of patient is over 180 mmHg. The selections: <OFF>, <ON>.
SYS HI LIM	Selects the warning upper limit of systolic blood pressure, the range is 0 ~ 300 mmHg continuously, and can not lower than the lower limit.
SYS LO LIM	Selects the warning lower limit of systolic blood pressure, the range is 0 ~ 300 mmHg continuously, and can not higher than the upper limit.
MAP HI LIM	Selects the warning upper limit of mean blood pressure, the range is 0~300 mmHg continuously, and can not lower than the lower limit.
MAP LO LIM	Selects the warning lower limit of mean blood pressure, the range is 0~300 mmHg continuously, and can not higher than the upper limit.
DIA HI LIM	Selects the warning upper limit of diastolic blood pressure, the range is 0 ~ 300 mmHg continuously, and can not lower than the lower limit.
DIA LO LIM	Selects the warning lower limit of diastolic blood pressure, the range is 0 ~ 300 mmHg continuously, and can not higher than the upper limit.
Review	Select this button for reviewing NIBP measurement data stored before.
STAT	Select this button will start continuous NIBP measurement within 5 minutes. No STAT measurement for neonate.
RESET	Select this button will reset NIBP module. This option is only used at periodic check or maintenance.
Air Leakage	Select this option will configure NIBP module work at air leakage check mode. This option is only used at periodic check or maintenance.



Note:

- **AUTO** measurement mode means the system automatically activates the air pump to conduct measurement according to the set intervals of cycles, **MANU** measurement mode means the user starts the air pump manually to conduct measurement, and **STAT** measurement mode means the system will swiftly and continuously measure BP within 5 minutes. **STAT** mode is invalid for neonate.
- While measuring hypertension patient, please set < High Press > on < ON >, so NIBP module can go up automatically to a higher pressure to start measuring, reduce the times of inflation, make the blood pressure measurement of hypertensive more quickly and accurately.

5.5.5 Review NIBP measurement

Select the **【NIBP】** --> **【Review】** , and a following NIBP review window will be displayed.

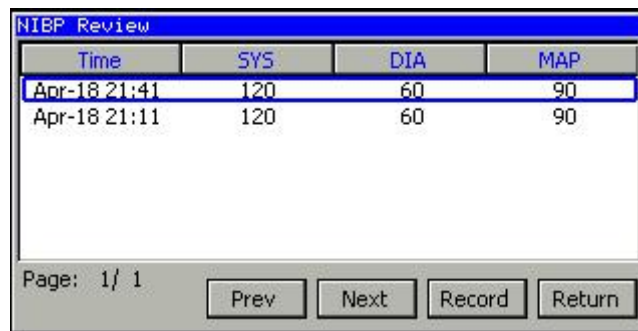

Prev	Turn to previous page.
Next	Turn to next page.
Record	Print the NIBP measurement results in current screen through recorder.
Return	Exit NIBP review window.



Note: The monitor can store maximum 600 items of NIBP measurement result. When the maximum storage capability is achieved, the monitor would not save new NIBP measurement data unless the old NIBP measurement cleared.

5.5.6 Display of NIBP parameter

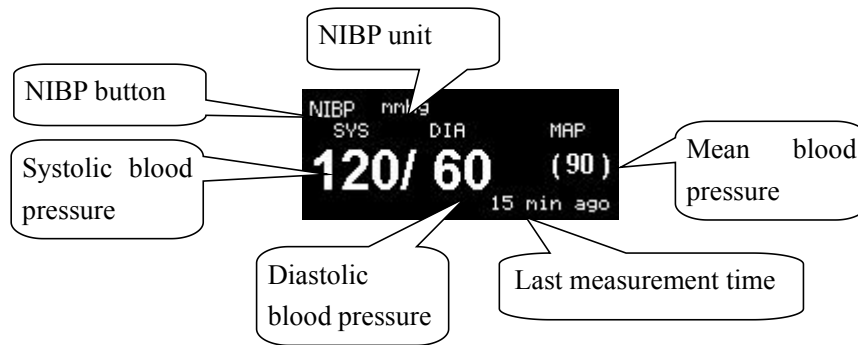

Fig. NIBP parameter area

5.5.7 Precautions during Measurement

⇒ If the BP of the patient is above 180mmHg, set **【 High Press 】** to <ON> is recommended.

⇒ When using the STAT measurement or AUTO measurement, if the time duration is relatively long, care must be taken to check such abnormalities as purple spots, coldness and numbness at the limb end. If there are such phenomena, the cuff should be relocated or the measurement of NIBP should be halted. **To neonate mode, STAT measurement is unavailable.**

⇒ The presence of factors that change the properties of the cardiovascular dynamics of patient will adversely affect the measurement value of the monitor, and shock and hypothermia will also affect the accuracy of the measurement.

⇒ When the built-in main artery balloon pump is applied on the patient, the measurement value of NIBP will be affected.

⇒ For the limb that is on an intravenous drip or in a catheter insertion, or if the patient is connected to the heart-lung machine, or the patient is experiencing shiver or convulsions, the measurement of NIBP cannot be conducted.

⇒ When errors occur in the measurement of NIBP, the error codes will appear in the parameter display area of the NIBP, and for the cause of the errors, please refer to **The NIBP Technical Alarm Information**.

5.5.8 Periodic Check

⇒ Calibration



Warning: The calibration of the NIBP measurement is necessary for every two years (of as frequently as dictated by your Hospital Procedures Policy). The performance should be checked according to the following details.

Procedure of the Pressure Transducer Calibration:

- 1) Replace the cuff of the device with a rigid metal vessel with a capacity of 500 ml $\pm 5\%$.
- 2) Connect a calibrated reference manometer with an error less than 0.8mmHg and a ball pump by means of a T-piece connector and hoses to the pneumatic system.
- 3) Access the <Maintenance> window.
- 4) Select the **【Manometer】** button and press. Then the prompt “Manometer test” will appear on the NIBP parameter area indicating that the system has started performing calibration.
- 5) Inflate the pneumatic system to 0, 50 and 200 mmHg by ball pump separately. The difference between the indicated pressure of the reference manometer and the indicated pressure of the monitor will not exceed $\pm 3\text{mmHg}$. Otherwise, please contact our customer service.
- 6) Press the  key on front panel can stop the calibration.

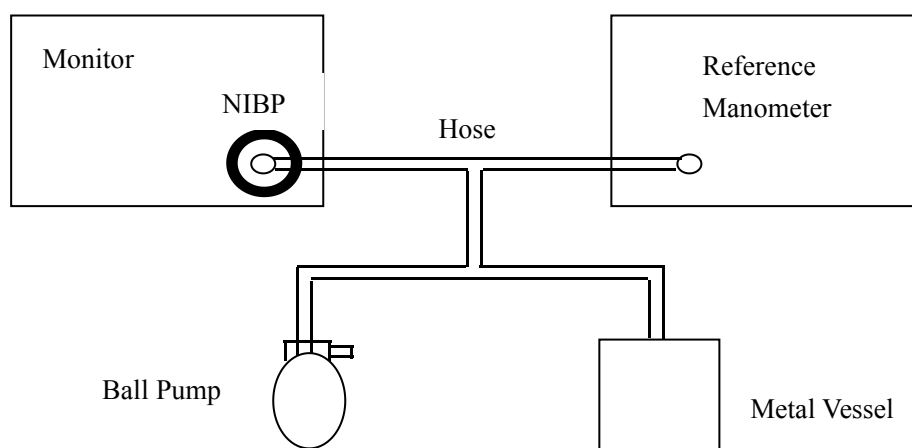



Fig. Diagram of NIBP calibration

Procedure of Safety Pressure Limits check:

- 1) Replace the cuff of the device with a rigid metal vessel with a capacity of 500 ml $\pm 5\%$.
- 2) Connect a calibrated reference manometer and a ball pump by means of a T-piece connector and hoses to the pneumatic system.
- 3) Access the <Maintenance> window.
- 4) Select the **【Adult Over Press】** button and press. Then the prompt “Over Pressure test” will appear on the NIBP parameter area indicating that the system has started performing Safety Pressure Limit test.
- 5) The Safety Pressure Limit in Adult mode is 315 ± 10 mmHg. Inflate the pneumatic system upper to this limits, the system will automatically open the deflating valve and the prompt “OVERPRESSURE SENSED” will appear on the

NIBP parameter area indicating that the system has completed an Safety Pressure Limit test.

- 6) Press the  key on front panel can also stop the test.
- 7) According to steps 1) - 7) for Safety Pressure Limit test of Child and Neonate modes. The Safety Pressure Limit in Child mode is 265 ± 10 mmHg and the Safety Pressure Limit in Neonate mode is 155 ± 10 mmHg.

☰ Air Leakage check

Procedure of the air leakage test:

- 1) Connect the cuff securely with the socket for NIBP air hole.
- 2) Wrap the cuff around the cylinder of an appropriate size.
- 3) Access the NIBP setup window.
- 4) Select the **【Air Leakage】** button and press. Then the prompt “Air Leakage test” will appear on the NIBP parameter area indicating that the system has started performing Air Leakage test.
- 5) The system will automatically inflate the pneumatic system to about 180mmHg.
- 6) After 20 seconds or so, the system will automatically open the deflating valve, which marks the completion of an air leakage test.
- 7) If no error information displays on NIBP parameter area, it indicates that the airway is in good situation and no air leaks exist. However if the prompt “AIR SYSTEM LEAK” appears in the place, it indicates that the airway may have air leaks. In this case, the user should check for loose connection. After confirming secure connections, the user should re-perform the air leakage test. If the failure prompt still appears, please contact the manufacturer for repair.
- 8) Press the  key on front panel can also stop the test.

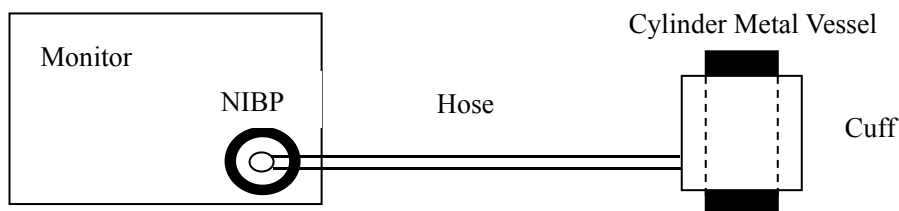

5.5.9 Maintenance and Cleaning

 **Warning: Do not squeeze the rubber hose on the cuff. Do not allow liquid to enter the connector socket at the front of the monitor. Do not wipe the inner part of connector socket when cleaning the monitor.**



Warning: if liquid is inadvertently splashed on the equipment or its accessories, or may enter the conduit or inside the monitor, contact local customer service center.

When the reusable cuff is not connected with the monitor, or being cleaned, always places the cover on the rubber hose to avoid liquid permeation.

■ **Reusable Blood Pressure Cuff**

The cuff can be sterilization be means of conventional autoclaving, gas, or radiation sterilization in hot air ovens or disinfected by immersion in decontamination solutions, but remember to remove the rubber bag if you use this method. The cuff should not be dry-cleaned.

The cuff can also be machine-washing or hand-washing, the latter method may prolong the service life of the cuff. Before washing, remove the latex rubber bag, and for machine-washing, close the Velcro fastening. Leave the cuff to dry thoroughly after washing, then reinsert the rubber bag.

To replace the rubber bag in the cuff, first place the bag on top of the cuff so that the rubber hoses line up with large opening on the long side of the cuff. Now roll the bag lengthwise and insert it into the opening on the long side of the cuff. Hold the hoses and the cuff and shake the complete cuff until the bag is in position. Thread the rubber hoses from inside the cuff, and out through the small hole under the internal flap.

■ **Disposable blood pressure cuffs**

Disposable cuffs are intended for one-patient use only. Do not use the same cuff on any other patient. Do not sterilize or use autoclave on disposable cuffs. Disposable cuffs can be cleaned using soap solution to prevent infection.



Disposal Notice: Should the blood pressure cuff become damaged beyond repair, or for some reason its useful life is considered to be at an end, please observe all local, state, and federal regulations that relate to the disposal of this products or similar products.

Chapter 6 Alarm

This chapter gives general information about the alarm and corresponding remedies.



Note: The equipment generates all the auditory and visual alarms through speaker, LED and screen.

6.1 Alarm Priority

There are two kinds of alarms, defined as physiological alarm and technical alarm. Physiological alarms refer to those alarms triggered by patient's physiological situation that could be considered dangerous to his or her life, such as SpO₂ exceeding alarm limit (parameter alarms). Technical alarms refer to system failure, which can make certain monitoring process technically impossible or make monitoring result unbelievable. Each alarm, either technical or physiological, has its own priority.

Alarms in the monitor are divided into three priorities, that is: high priority, medium priority and low priority.

- High priority alarm indicates the patient's life is in danger. It is the most serious alarm.
- Medium priority alarm means serious warning.
- Low priority alarm is a general warning.

Only alarm priority of parameters exceeding limits alarm can be modified by the user, the other alarm priorities of physiological and technical alarms are preset by the system and they can not be changed by the user.

6.2 Alarm Modes

When alarm occurs, the monitor may raise the user's attention in two ways, which are auditory prompt, visual prompt and description. Visual prompt is given by alarm indicator lamp of the monitor, auditory prompt is given by speaker in the device. Physiological alarm information is displayed in the Physiological Alarm area. Most of technical alarm information is displayed in the Technical Alarm area. Technical alarms related to NIBP measurement are displayed in the NIBP parameter area.

The alarm sound and visual display comply with clause 201.3.2 of the standard IEC 601-1-8.

 **Note: The concrete presentation of each alarm prompt is related to the alarm priority.**

☰ Alarm sound

The high/medium/low-level alarms are indicated by the system in following different audio ways:

Alarm level	Audio prompt
High	Mode is “DO-DO-DO-----DO-DO, DO-DO-DO-----DO-DO”, which is triggered once every 10 seconds.
Medium	Mode is “DO-DO-DO”, which is triggered once every 25 seconds.
Low	Mode is “DO-”, which is triggered once every 25 seconds.

☰ Lamp light

Alarm level	Visual prompt
High	Alarm indicator flashes in red with 2 Hz.
Medium	Alarm indicator flashes in yellow with 0.5 Hz.
Low	Alarm indicator lights on in yellow.

☰ Screen Display

Physiological alarm: The parameter, which triggers the alarm, splashes in the frequency of 2Hz on the screen. The physiological alarm area displays alarm message, and red “***” indicates high priority alarm, yellow “**” indicates medium priority alarm, yellow “*” indicates low priority alarm.

Technical alarm or General message: The technical alarm area provides text prompt, red “***” indicates high priority alarm, yellow “**” indicates medium priority alarm, yellow “*” indicates low priority alarm, cyan indicates general message.

 **Note: When alarms of different priorities occur at the same time, the monitor prompts the one of the highest priority.**

6.3 Alarm Setup

☰ Set Alarm volume

Select **【MENU】** --> **【ALM volume】**, options are 0~3. Select 0 to close the alarm sound, Select 3 to setup maximal alarm volume.

The alarm sound is closed, that is to say, when an alarm takes place, the monitor will not make any sound.

☰ **Set alarm limits of physiological parameters**

The alarm limit of each physiological parameter can be set in its menu, and they are continuous in alarm range. For example:

ECG alarm setup:

1. Select <ECG> button
2. Configure the following parameters related to ECG alarm, <ALM Level>, <ALM REC>, <HR LO LIM> and <HR HI LIM>.

Please refer to above operation for Methods of Alarm setup of the other parameters

It is important to set physiological alarm limits properly. The monitor can't give medicinal alarm prompt in clinical application with improper setting of physiological alarm limit.

The physiological alarm occurs when the measurement exceeds the set parameter limits.

Please refer to above operation for Methods of alarm setup of the other parameters.

☰ **Alarm indication of physiological parameters**

Auditory: when alarm occurs, the system generates alarm sound to raise the user's attention (auditory alarm can be disabled).





Visual: The parameter flashes on the display area of the screen and alarm indicator lights.

 **Warning: The lower limit and the upper limit of parameter must be set based on clinical practices and general clinical experiences.**

 **Note: When parameter alarm level is off, alarm will be disabled, even if the measurement results exceed the limits.**

6.4 Alarm state icon



According to alarm setup of the monitor, the following icons would be displayed on screen.

-  The alarm is suspended.
-  The system sound is silenced.
-  The alarm sound is off.
-  The parameter alarm is off.

The system sound includes alarm sound and QRS sound.



6.5 SILENCE/ALARM PAUSED

☰ SILENCE

Press the  key on the front panel for more than 2 seconds can shut off all sounds until the  key is pressed again. When the system is in SILENCE status, any newly generated alarm will cancel the SILENCE status and make the system back to normal status giving auditory alarm prompt.



When in the SILENCE status, the icon  will be displayed in the right undersurface of the screen.

☰ ALARM PAUSED

Press the  key on the front panel for less than 2 seconds can close all auditory and visual prompt and description about all the physiological alarms and to make the system enter ALARM PAUSED status. The rest seconds for ALARM PAUSED is displayed in the Physiological Alarm area . And the icon  will be displayed in the physiological alarm area.

The user may set up the time for ALARM PAUSED. Select **【MENU】** --> **【ALM Paused】**, two selections are available: 1, 2 minutes.

When in the ALARM PAUSED status, press the  key again to restore the normal alarm status. Besides, during ALARM PAUSED status, newly occurring technical alarm will cancel the ALARM PAUSED status and the system will come back to the normal alarm status.

 **Note: Whether an alarm will be reset depends on the status of the alarm cause. But by pressing  key can permanently shut off audio sound of Lead Off/Sensor Off alarms.**

6.6 Parameter Alarm

The setup for parameter alarm is in their menus. In the menu for a specific parameter, you can check and set the alarm limit, alarm status. The setup is isolated from each other.

When a parameter alarm level is off, the icon  displays near the parameter.

For the parameters whose alarm level is not off, the alarm will be triggered when at least one of them exceeds alarm limit. The following actions take place:

1. Alarm message displays on the screen as described in alarm mode;
2. The monitor beeps in its corresponding alarm level and volume;
3. If alarm recording is on, the recorder starts alarm recording at set interval.

6.7 When an Alarm Occurs



Note: When an alarm occurs, you should always check the patient's condition first.

Check the alarm message appeared on the screen. It is needed to identify the alarm and act appropriately, according to the cause of the alarm.

1. Check the patient's condition.
2. Identify which parameter is alarming or which kind of alarm it is.
3. Identify the cause of the alarm.
4. Silence the alarm, if necessary.
5. When cause of alarm has been over, check that the alarm is working properly.

You will find the alarm messages for the individual parameter in their appropriate parameter chapters of this manual.

6.8 Alarm Description and Prompt

6.8.1 ECG alarm information

Physiological Alarm Information:

Message	Cause	Alarm Level
HR too high	HR measuring value is above the upper alarm limit	User-Selectable
HR too low	HR measuring value is below the lower alarm limit	

Technical Alarm Information:

Message	Cause	Alarm Level
RA/LA/LL/V- OFF LEADS OFF	ECG electrode fall off the patient's skin or ECG cables fall off the monitor	Low
ECG Signal Saturated	ECG electrode polarized	Low

6.8.2 RESP alarm information

Physiological Alarm Information:

Message	Cause	Alarm Level
RR too high	RR measuring value is above the upper alarm limit	User-Selectable
RR too low	RR measuring value is below the lower alarm limit	
RESP Apnea	No signal for breath in specific interval	

6.8.3 SpO₂ alarm information

Physiological Alarm Information:

Message	Cause	Alarm Level
SpO ₂ too high	SpO ₂ measuring value is above the upper alarm limit	User-Selectable
SpO ₂ too low	SpO ₂ measuring value is below the lower alarm limit	
PR too high	PR measuring value is above the upper alarm limit	
PR too low	PR measuring value is below the lower alarm limit	
SpO ₂ Pulse timeout	Search pulse too long, weak signal	High

Technical Alarm Information:

Message	Cause	Alarm Level
SpO ₂ OFF	SpO ₂ sensor may be disconnected from the patient or the monitor	Low
SpO ₂ Motion	There us some interference signal or great patient motion	Defined by the degree of motion
SpO ₂ sensor failure	SpO ₂ sensor failure	Low

Prompt:

Message	Cause	Alarm Level
SpO ₂ Search pulse	SpO ₂ module is searching for pulse	No alarm

6.8.4 TEMP Alarm information

Physiological Alarm Information:

Message	Cause	Alarm Level
T1 too high	TEMP1 measuring value is above upper alarm limit	User-Selectable

T1 too low	TEMP1 measuring value is below lower alarm limit	User-Selectable
T2 too high	TEMP2 measuring value is above upper alarm limit	User-Selectable
T2 too low	TEMP2 measuring value is below lower alarm limit	User-Selectable
TD too high	The difference between channel 1 and channel 2 TEMP is above upper alarm limit	User-Selectable

Technical Alarm Information:

Message	Cause	Alarm Level
T1 OFF	TEMP1 sensor may be disconnected from monitor	Low
T2 OFF	TEMP2 sensor may be disconnected from monitor	Low
T1 OH	TEMP1 over upper measuring range	Low
T1 OL	TEMP1 below lower measuring range	Low
T2 OH	TEMP2 over upper measuring range	Low
T2 OL	TEMP2 below lower measuring range	Low
TEMP Self checking error	TEMP module self check failure	Low

6.8.5 NIBP Alarm

Physiological Alarm Information:

Message	Cause	Alarm Level
SYS too high	NIBP SYS measuring value is above upper alarm limit	User-Selectable
SYS too low	NIBP SYS measuring value is below lower alarm limit	
DIA too high	NIBP DIA measuring value is above upper alarm limit	
DIA too low	NIBP DIA measuring value is below lower alarm limit	
MAP too high	NIBP MAP measuring value is above upper alarm limit	
MAP too low	NIBP MAP measuring value is below lower alarm limit	

Technical Alarm Information (Displayed in NIBP parameters display area):

Message	Cause	Alarm Level
SELF-TEST FAILED	Transducer or other hardware failure.	Low
LOOSE CUFF	a. Cuff is completely unwrapped. b. The cuff is not connected. c. Adult cuff used in neonate mode.	Low
AIR LEAK	Air leak in pneumatics, hose, or cuff.	Low
AIR PRESSURE ERROR	Unable to maintain stable cuff pressure, e.g. kinked hose	Low
WEAK SIGNAL	a. Very weak patient signal due to a loosely wrapped cuff. b. The pulse of patient is too weak.	Low
RANGE EXCEEDED	Measurement range exceeds module specification.	Low
EXCESSIVE MOTION	a. Too many retries due to interference of motion artifact. b. Signal is too noisy during measurement, e.g. patient has severe tremor. c. Irregular pulse rate, e.g. arrhythmia.	Low
OVERPRESSURE SENSED	Cuff pressure exceeds the specified upper safety limit. Could be due to rapid squeezing or bumping of cuff.	Low
SGNAL SATURATED	Large motion artifact that saturates the BP amplifier's amplitude handling capability.	Low
AIR SYSTEM LEAK	Module reports Air Leakage failure while in the Pneumatic Test mode.	Low
SYSTEM FAILURE	Module occurs abnormal processor event.	Low
TIME OUT	Measurement took more than 120 seconds in adult, 90 seconds in neonate mode.	Low
CUFF TYPE ERR	Neonate cuff used in adult mode.	Low

Prompt (Displayed in NIBP parameters display area):

Message	Cause	Alarm Level
Resetting...	Module is reset.	No alarm
Over Pressure test	Module is in the Over Pressure Test mode.	

Manometer Testing	Module is in the Manometer Test mode.	No alarm
Air Leakage Testing	Module is in the Pneumatic Test mode.	

6.8.6 System Alarm and Prompt

Technical Alarm Information:

Message	Cause	Alarm Level
Battery failure	Battery failure	Low
BATTERY LOW	Energy of battery is exhausted.	Medium
KB ERR	Keyboard error	Low
REC ERR	No paper in the recorder or the recorder door is open.	Low
RTC RESET	System time error, user should reset the system time.	Low
RTC USELESS	System time failure.	Low
ECG communication error	ECG module failure or communication failure	Low
SpO ₂ communication error	SpO ₂ module failure or communication error	Low
TMEP communication error	TEMP module error or communication error	Low
NIBP communication error	NIBP module failure or communication failure	Low

Prompt Information

Message	Cause	Alarm Level
Wave Frozen	The waveform display on the screen is frozen.	No alarm

Chapter 7 Recording

- ☰ **The monitor carries out the recording function by a built-in recorder optional.**



This icon will be displayed in the system information area of the screen when the monitor has been equipped with a recorder.



This icon will be displayed in the system information area of the screen when the recorder is lack of paper, the door is not closed or other faults.

- ☰ **Alarm recording**

The monitor has the function of alarm trigger recording.

- Select **【MENU】** --> **【Recorder...】** --> **【ALM REC Interval】**, setup the alarm recording interval when alarm is occurring continuous. Alarm recording function will be disabled when <OFF> is selected.
- Access the parameter setup windows and set the **【ALM REC】** to <ON>, and setup the parameter alarm level and alarm limit correctly.
- When the parameter alarm occurs and the **【ALM REC】** is <ON>, all the parameter values during the alarm will be printed out. And the parameter value which trigger the alarm recording will be marked with “*”.
- If duration of the parameter alarm is over alarm recording interval, the monitor will print out all the parameter values again.



Note: The <ALM REC> is included in any parameter setup menu. If the option is at <OFF>, the parameter alarm cannot trigger the alarm recording.

- ☰ **Auto recording**

The monitor has the function of auto recording.

- Select **【MENU】** --> **【Recorder...】** --> **【Auto REC】**, setup interval time of auto recording.
- Select **【MENU】** --> **【Recorder...】** --> **【REC Length】**, setup the recording length of waveform in auto recording.
- The monitor prints out waveforms and parameter values according to interval time set in **【Auto REC】**.

- ☰ **Real-Time Recording**

The monitor has the function of real time recording. Press the  key on front

panel to start the real-time recording of waveforms and parameter values, press the key again to end the real-time recording. The ECG waveform recorded is selected by **【Select Lead】** in ECG Setup window.

Chapter 8 The Maintenance and Cleaning

8.1 System Check

An effective maintenance schedule should be established for your monitoring equipment and reusable supplies. This should include inspection as well as general clearing on a regular basis. The maintenance schedule must comply with the policies of your institution's infection control unit and/or biomed department.

Check with your Biomedical department to be sure preventive maintenance and calibration has been done. The User Maintenance Instruction contains detailed information.

Before using the monitor, check the equipment following these guidelines:

- ⇒ Check the equipment for obvious mechanical damage.
- ⇒ Check all the outer cables, inserted modules and accessories for fraying or other damage. Qualified service personnel should repair or replace damaged or deteriorated cables.
- ⇒ Check all the functions relevant to patient monitoring, make sure that the monitor is in good condition.

If you find any damage on the monitor, stop using the monitor on patient, and contact the biomedical engineer of the hospital or Manufacturer's Customer Service immediately.



Note: Refer to the User Maintenance Instruction for more comprehensive checkout procedures.

The overall check of the monitor, including the safety check, should be performed only by qualified personnel once every 6 to 12 month, and whenever the monitor is fixed up.

- Inspect the safety relevant labels for legibility.
- Verify that the device functions properly as described in the instructions for use.
- Test the protection earth resistance according IEC 601-1:1988, Limit 0.1ohm.
- Test the earth leakage current according IEC 601-1:1988, Limit: NC 500uA, SFC 1000uA.
- Test the patient leakage current according IEC 601-1:1988, Limit: 100uA(BF), 10uA(CF).
- Test the patient leakage current under single fault condition with mains voltage on the applied part according IEC 601-1:1988, Limit: 5mA(BF), 50uA(CF).

The leakage current should never exceed the limit. The data should be recorded in an equipment log. If the device is not functioning properly or fails any of the above tests, the device has to be repaired.

The synchronism of the defibrillator should be checked by in the frequency described in the hospital regulations. At least every 3 months, it should be checked by the biomedical engineer of the hospital or qualified service technician.

All the checks that need to open the monitor should be performed by qualified service technician. The safety and maintenance check can be conducted by persons from the manufacturer. You can obtain the material about the customer service contract from the local office.

The circuit diagrams, parts lists and calibration instructions of the patient monitor can be provided by the manufacturer.

 **Warning: If the hospital or agency that is responding to using the monitor does not follow a satisfactory maintenance schedule, the monitor may become invalid, and the human health may be endangered.**

 **Note: To ensure maximum battery life, please ensure that the battery is always fully charged when you are keeping the device in storage for an extended period of time, and check the battery status at least once every month and recharge the battery.**

 **Warning: Refer the battery replacement only to manufacturer's service technician.**

8.2 Battery Maintenance

A built-in rechargeable battery is designed for the patient monitor, which enables continuous working when AC power off. Special maintenance is not necessary in the normal situation. Please pay attention to the followings in using for more durable usage and a better capability.

⇒ Operate the patient monitor in the environment according to the specification of this manual.

⇒ Use AC power for the patient monitor when available.

⇒ Recharge the battery sooner when it is off. The volume of battery will not be charged to what it should be, when the battery has not been charged for a long time.

⇒ Recharge the battery for every half a year when the patient monitor is not operated for a long period.

⇒ Avoid exposed and sun shine.

⇒ Avoid infrared and ultraviolet radiation.

⇒ Avoid moist, dust and erosion from acid gas.

8.3 General Cleaning

 **Warning: Before cleaning the monitor or the sensors, make sure that the equipment is switched off and disconnected from the power line.**

The Patient Monitor must be kept dust-free.

Regular cleaning of the monitor shell and the screen is strongly recommended. Use only non-caustic detergents such as soap and water to clean the monitor shell.

Please pay special attention to the following items:

1. Avoid using ammonia-based or acetone-based cleaners such as acetone.
2. Most cleaning agents must be diluted before use. Follow the manufacturer's directions carefully to avoid damaging the monitor.
3. Don't use the grinding material, such as steel wool etc.
4. Don't let the cleaning agent enter into the chassis of the system.
5. Don't leave the cleaning agents at any part of the equipment.

8.4 Cleaning Agents

Examples of disinfectants that can be used on the instrument casing are listed below:

- Diluted Ammonia Water
- Diluted Sodium Hypochlorite (Bleaching agent).

 **Note: The diluted sodium hypochlorite from 500ppm (1:100 diluted bleaching agent) to 5000ppm (1:10 bleaching agents) is very effective. The concentration of the diluted sodium hypochlorite depends on how many organisms (blood, mucus) on the surface of the chassis to be cleaned.**

- Diluted Formaldehyde 35%--37%
- Hydrogen Peroxide 3%

- Alcohol 75%
- Isopropanol 70%

The patient monitor and sensor surface can be cleaned with hospital-grade ethanol and dried in air or with crisp and clean cloth.

The manufacturer has no responsibility for the effectiveness of controlling infectious disease using these chemical agents. Please contact infectious disease experts in your hospital for details.

8.5 Sterilization

Sterilization needed for the following parts.

➤ For cuff

1. To clean for normal hygienic purposes, wipe with a mild soap and water solution.
2. Do not immerse in chemicals/ detergent or water. Accidental entry of liquid into the tubing or bladder can ultimately damage the monitor.

➤ For Temperature Probe

Ethylene oxide is the preferred sterilization method, after sterilization, probes must be safely and thoroughly ventilated before handling or use. Using a generic EtO sterilizing procedure, we recommend an aeration time of 12 hours minimum to dissipate residual EtO in the probe below 250 ppm.

➤ For SpO₂ probe

1. Saturate a clean, dry gauze pad with the cleaning solution. Wipe all surfaces of the sensor and cable with this gauze pad.
2. Saturate another clean, dry gauze pad with sterile or distilled water. Wipe all surfaces of the sensor and cable with this gauze pad.
3. Dry the sensor and cable by wiping all surfaces with a clean, dry gauze pad.

Do not sterilize by irradiation, steam, or ethylene oxide.

➤ For ECG/RESP cable

To avoid extended damage to the equipment, sterilization is only recommended when stipulated as necessary in the hospital maintenance schedule. Sterilization facilities should be cleaned first.

Recommended sterilization material:

Ethylate: 70% alcohol, 70% isopropanol

Acetaldehyde

No sterilization needed for ECG electrodes and other disposable parts.

Please pay special attention to the following items:

- **Do not let liquid enter the monitor.**
- **Do not pour liquid onto the monitor during sterilization.**
- **Use a moistened cloth to wipe up any agent spilled on the monitor.**

8.6 Disinfection

To avoid extended damage to the equipment, disinfection is only recommended when stipulated as necessary in the Hospital Maintenance Schedule. Disinfection facilities should be cleaned first.

Appropriate disinfection materials for ECG lead, SpO₂ sensor, blood pressure cuff, TEMP probe are introduced in the corresponding chapters respectively.



Warning: Do not use EtO gas or formaldehyde to disinfect the monitor.

Brief Introduction to the defibrillator Part

1. SAFETY INSTRUCTION

Before you use defibrillator , read the following tips carefully to get a good and safe use and to avoid possible damage to human beings:

1. Please read the entire manual carefully to understand its proper operation before use.
2. The unit can be only applied to the specified use in the manual. No other using ways to avoid possible danger.
3. Like other defibrillators, the unit should keep away from explosive and dangerous place.
4. Any alterations or modifications to the unit should be done by the qualified and trained person from our company.
5. The unit could adapt with the parts which are approved by the legal quality department. All the original parts are checked before leaving our factory.
6. Check the unit whether in normal and safe condition before use. For example, don't use the defibrillator if the wire is damaged.
7. Special notice to the instructions in appendix A1 during operation.
8. When using the defibrillator, be sure that no instrument sensitive to the magnetic field(such as measuring one) or possible disturbance sources in the neighborhood keep distance from them.
9. The max energy charging time is 15 seconds. The discharge should not be over three times per minutes. The unit is OK of certain cooling time.

Besides. Our unit conforms to the requirements of general provisions for Medical Equipment

1. BOARD DISPLAY

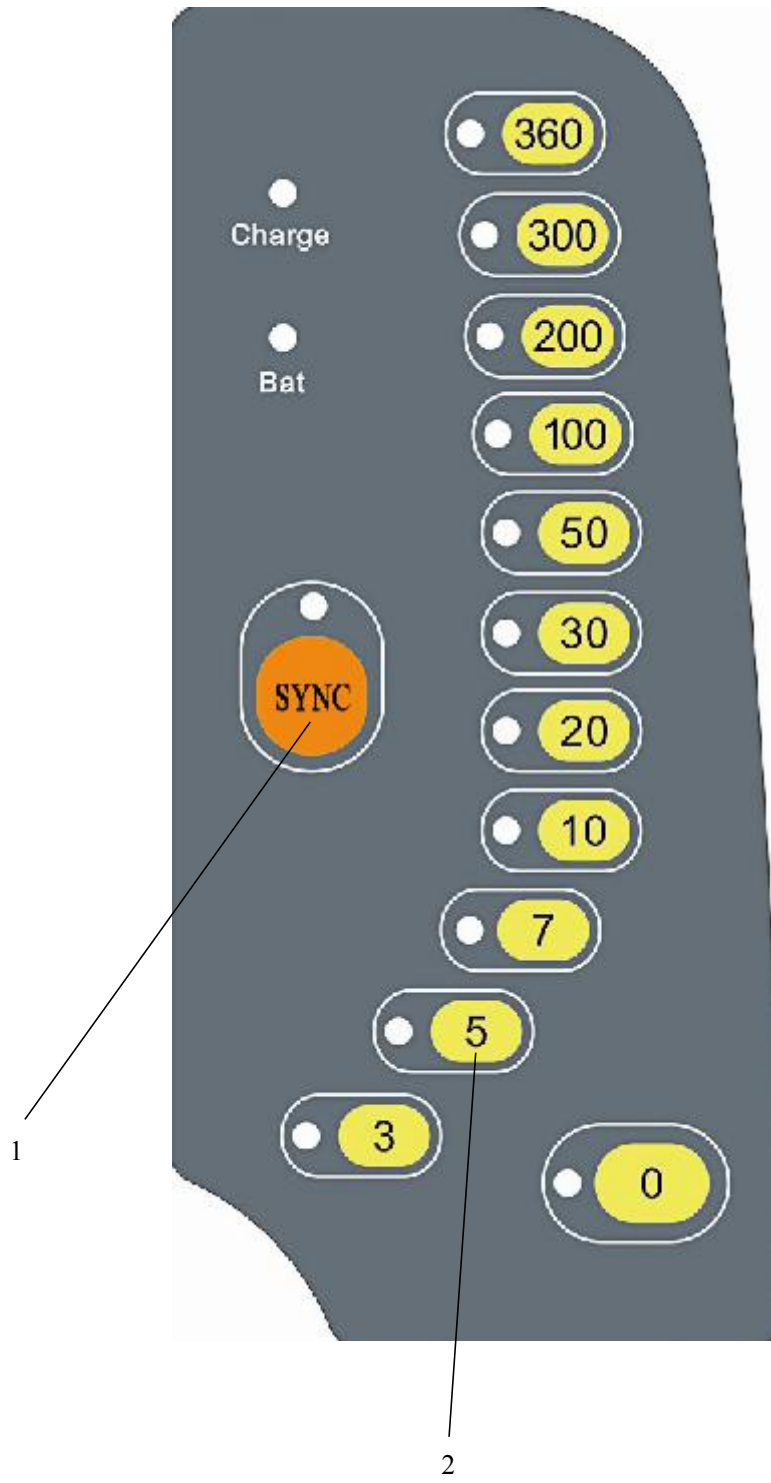

- (1) SYNC or NON SYNC mode
- (2) ENERGY SELECTOR To select the energy of the heart defibrillating treatment.

3. OPERATION INSTRUCTION

(1) First plug the power cord into the outlet well.

(2) Put the ON/OFF defi power switch to "1" place. Then the indicating lamp in top of energy selector "0" step will light.

Note: If the buzzer beeps 4 times, that is the failure warning of the batteries or power supply.

(3) Energy selector: Press the button (2) to choose a energy step. If the lamp on top of the button lights, that is to indicate the energy of selected step is full and is ready to do defibrillating discharge. If with full energy, but no discharge or use, press "0" step selector to do inner discharge and zeroing the energy.

(4) Electrode position: Hold the hand of the electrode, and get them from the block on the unit. The electrode pad should be placed along with the hear axis. APEX pad should be placed on the victim's left heart, above auxiliary line of apex cords. The other should be at the right chest, below the clavicle.

Note: To protect from the skin burning, it is very important to put enough conductive gel on the pad surface.

Note: The two electrode pads should be pressed firmly with around 10 kilograms force to make the safe energy transfers and prevent from possible skin burning

Note: Make sure no connecting and transferring gel between two electrodes.

(5) Energy discharge: Press the release key on two pads at the same time for discharge.

Note: The buzzer will beep 1 time once the discharge finish normally.

Note: The buzzer will beep 3 times once the discharge finish abnormally, which happens when the paddles are in the air or the contact resistance between paddles and victim.

Note: Before and During the discharge, all the participants to revival treatment should keep distance, and away from the conductive objects(such as stretcher) and the ones connected with the victim. All other instrument connected with the victim should get away from the victim before discharge.

Note: Avoid the connection of two pads to discharge. This will cause short circuit.

Note: After full charge of the energy, please press "0" key for internal discharge if not use.

4. Maintenance

Put off the power plug when surely the unit is closed.

It is OK to clean with the home detergent. Please use the clean cloth then.

It is also OK to sterilize the electrode pads with common medical ethanol or disinfectant.

Note: Don't use the cloth of water dropping for cleaning. The dropping water may affect the performance of the unit. Also don't put the unit into the water.

No matter use or not of the unit, we recommend the operator to check and maintain the defibrillator and its parts. Please notice the following tips for maintain

1. Check whether the outer case is OK or damaged
2. Check the conducting wire of electrodes is OK or insulation damage
3. Clean all the conductive gel and dirty on the two pads and other electrodes, so as to make sure the good connection and avoid the electric spark.

In order to make the good function of defibrillator, the unit should equip with a charging battery that can work well. The battery of the unit can support 10 times discharge.

The operator can full charge of the electricity and then discharge to verify the times.

Note: The unit should be repaired directly damage of outer case or loss of electricity.

5. Technical features

Defibrillation

Driving terms: Biphasic, synchronous/asynchronous, external defibrillating treatment

Energy steps: 0、3、5、7、10、20、30、50、100、200、300、360 joule (50ohm) twelve steps available

Charging time: <10 seconds (360joule)

Pad electrode: Adult type(pediatric integrated)

Safety:

Series: Protect step II , type: electrocardiogram C F, Others is B F, 25th group of Medical instrument manufacture

Others:

Working power: AC/DC: AC 220V/50Hz or 110V/60Hz(*); 12Vchargable battery for DC

Battery capacity: +10timesreserve (360joule)

Normal working condition:

Working temperature: 5~40℃

Relative temperature: ≤80%

Atmospheric pressure: 86kpa~106kpa

*Before connect the power cord to the outlet, please check the power supply condition mared in the label located in the back of this equipment's shell.

6. Warranty terms

Our company will support one-year warranty against the purchasing date (consumables and attached excluded). During the warranty, our company will free remove all the problems and defects caused by the materials or manufacture. We will repair or change one for the fault machine. The implement of responsibility will not prolong the original warranty time.

The requirements of all other contracts' terms or beyond this contract will be excluded. Otherwise these terms are specified, oversighted, or subject to the obligatory legal regulations or laws.

Regarding the damage caused by the wrong operation not according to the instruction, violent action, illegal repairing not done by the authorized person, our company will be not responsible. The warranty requirements from distributors (agents) to purchaser is beyond this regulation.

If warranty is needed, please contact with your distributors (agents). Or Deliver all the purchasing documents of our machine, such as invoice, your name, address to our technical department. Even beyond the warranty time, our company will try our best to serve you.

Appendix

A1 General instructions and regulation of operating the defibrillator.

What is cardiac defibrillation?

Cardiac defibrillation is to release the current to the electrical muscle, so as to cause contracting, and the myocardial depolarization. So that this can remove the abnormal heart's rhythmic patterns, which will be dangerous to the life. The abnormal heart's rhythm is the incompatible between the heart muscle and the physical action.

Abnormal heart's rhythm	Possible treatment
1. Incompatibly of active parts of heart muscle (e.g. quivering of the heart)	1. Synchronous DC defibrillation
2. Complete abnormal of heart muscle beat (Ventricular flutter)	2. Asynchronous DC defibrillation (heart defibrillate)

The above table offers two common abnormal heart's rhythm cases and the related possible treatments for that. Actually the cardiac defibrillator is designed especially for asynchronous defibrillation, so this is not available in the synchronous one.

Also the above DC defibrillations are different. Here we briefly discuss about it.

(1)Asynchronous DC defibrillation (heart defibrillate)

No prolong when using this way. Just release the energy immediately press the “discharge” switch. The precondition is the correctness of cardiac fibrillation diagnosis and pulse Defects.

If the defibrillator’s energy asynchronously releases to the heart rhythm, this will damage the heart. If the energy affects to the heart muscle at heart refractory Period(around half of T-wave), it will aggravate the heart quivering.

(2). Synchronous DC defibrillation

The precondition of this defibrillation is that the victims have distinguished heart rhythm. As to the synchronous discharge, the Electrocardiogram will have clear QRS Composite wave. Some millisecond(about 10-60) after R-wave detection, the synchronous mechanical system from ECG part will control to discharge.

The ECG parts will indicate “SYNC” to show the detection of QRS composite wave for doctors’ easy operation.

When using, the discharge doctor should carefully note of the signal and make sure that each QRS composite waves are legible. Also they are not interfered by others or cardiac pulse synchronization

Steps for the heart defibrillation(Asynchronous DC defibrillation)

The following treatment steps only applies to the heart defibrillator. This does not apply to the machinery, cardiopulmonary or pharmacological recovery fields. The basic premise of synchronous DC defibrillation is ventricular fibrillation, which means that in the victims’ electrocardiogram have P-QRS wave or T wave defects.

1. Open the defibrillator

2. Put the conductive gel on the two electrode pads.

Remember enough gel on the pads in order to reduce transmission resistance and more energy into the victims. Too little gel possibly causes the skin burning under the pads.

Note: No gel to the hand of the electrode pads. Otherwise, it is dangerous to transfer the electric spark to the operator or doctor.

3. Energy selection

The discharging energy confirms with the victims’ height and weight. It is around 2 joule/kgs. Also it is according to experiences and the specific aid situation.

4. Position of electrode pads

The pads should be firmly pressed on the victims’ naked chest. Also for the safe energy

transmission, it is necessary to press with around 10kilograms force. Too small force will also cause the skin burning. It is necessary to do practice on the training instrument for the correct position.

The pads position is crucial to the successful recovery. So the current between the electrodes should transfer the chest to myocardial tissue. Only when 80% heart being defibrillating, and get to “critical mass”, possibly the fibrillation can be over.

Wrong position of electrode pads will cause large loss of current from the heart side without any effect.

Correct position of sternum electrode: —Right Chest
—Right side of sternum
—Beneath the clavicle

Correct position of pole electrode —Beneath the left chest
—Above apex
—Center of auxiliary line

Note: Don't put the conductive gel on the electrodes on the victims' chest. If not, the current will only flow through the electrode surface. The gel also could not be on the hand of electrode pads. If not, it may form electric spark and danger to the doctor.

5. Protection before electrode discharge

Before the defibrillation, the doctor in charge should very clearly tell all the participants for recovery aid away from the victim, the bed and the connected instrument. All other instrument that is not used to defibrillation treat should remove from the victim. If not, it is possible to cause spark on other participants

6. Discharge the energy

Press the release key on the pads at the same time. The defibrillator will do the discharge.

7. Observe the result

After defibrillation, it is necessary to diagnose the victim situation and the patient monitor. According to the observing result, if necessary, more defibrillation will be done for the treatment(Repeat steps 3-7 again)

If using artificial or pharmacological measures for assistant, the emergency doctor should do the guarantee and be responsible for that.

8. Make sure that the defibrillator in good condition

After the treatment, you should clean the electrode pads, electrodes and wires for next good use.

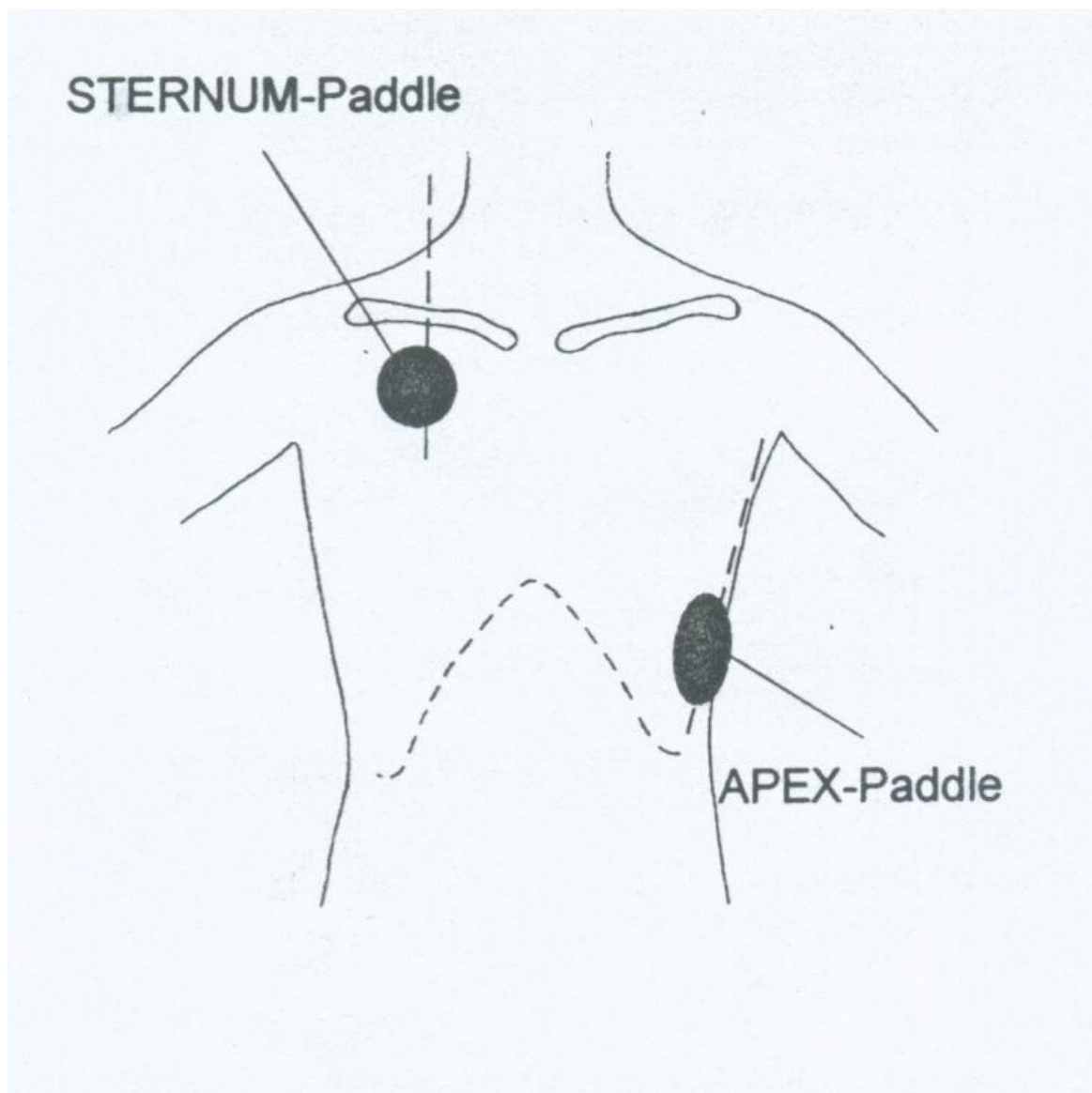

A2:The use of paddles

Our company's defibrillator use the composite paddles, an external paddle for adults, built-in paddles for children. If you need to use the children's paddle, the adult's paddle should be spun. After used, if you need to resume the paddle, please first clean up the electrode of the children paddle, then spin again. Must be tightened up and good in keep in touch.

